

Synthesis of a Core Arabinomannan Oligosaccharide of *Mycobacterium tuberculosis*

Alexandra Hölemann,[†] Bridget L. Stocker,[†] and Peter H. Seeberger*

Laboratory for Organic Chemistry, Swiss Federal Institute of Technology (ETH) Zürich,
Wolfgang-Pauli-Strasse 10, HCI F 315, CH-8093 Zürich, Switzerland

seeberger@org.chem.ethz.ch

Received June 15, 2006

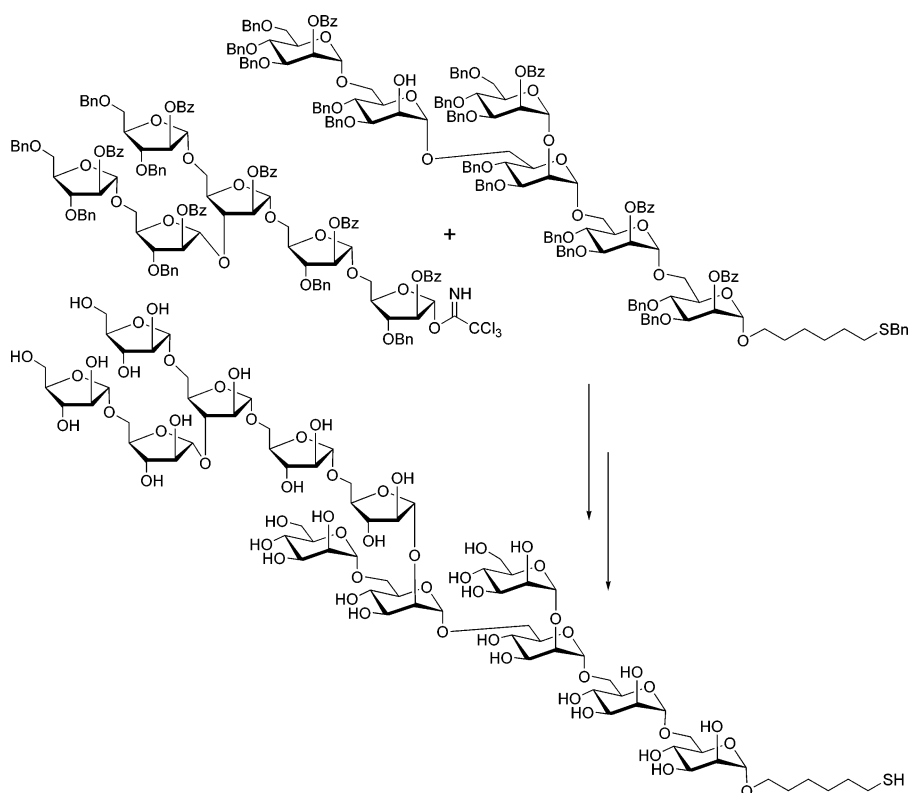

The synthesis of a core arabinomannan (AM) oligosaccharide from *Mycobacterium tuberculosis* has been achieved using a convergent [6 + 6] glycosylation strategy and a defined set of building blocks. Dodecasaccharide **1**, containing the key AM structural features of lipoarabinomannan (LAM), was obtained in excellent yield and selectivity from hexamannan **3** and hexaarabinan **5**. This flexible synthetic strategy involves late-stage couplings and modifications, thus providing ready access to several different LAM fragments. The incorporation of a thiol linker at the reducing end of the oligosaccharide allows for the attachment of these compounds to microarrays and protein carriers.

Introduction

Tuberculosis (TB) is one of the most devastating infectious diseases in the world. The result of infection by *Mycobacterium tuberculosis*, TB is estimated to infect eight million people and

cause two million deaths annually—a mortality rate that makes TB one of the three most serious infectious diseases alongside HIV and malaria.¹ Indeed, it is this co-infection with HIV,²

(1) The World Health Organization. <http://www.who.int/tb/en/>.

(2) Dolin, P. J.; Raviglione, M. C.; Kochi, A. *Bull. World Health Org.* **1994**, *72*, 213–220.

[†] These authors contributed equally.

togetherwith the emergence of multiple-drug resistant strains of *M. tuberculosis*,³ limited treatment regimes,⁴ and the increase in global travel that has led to a rapid increase in the number of reported TB cases. In 1993, the World Health Organization (WHO) declared TB a “global health emergency”.

Much of the pathogenicity of *M. tuberculosis* results from its unique and complex cell envelope. The major components of this mycobacterial envelope are the mycolyl arabinogalactan–peptidoglycan complexes (mAGPs) and the lipoarabinomannan (LAM)-associated lipoglycans.⁵ Combined, both form a thick cellular envelope that aids in the bacteria’s ability to survive within the host and to resist antibiotic treatment.⁶ It is generally believed that LAMs are also implicated in the immunogenicity of *M. tuberculosis*. LAMs have been shown to inhibit T-cell activation,⁷ protein kinase C activity,⁸ and various INF- γ induced functions including macrophage microbicidal and tumoricidal activity.⁹ They also induce a large array of cytokines associated with macrophages such as TNF- α ,^{5b,10} granulocyte-macrophage-CSF, IL-1a, IL-1b, IL-6, and IL-10.^{5b,10c} Furthermore, oligosaccharides, derived from LAM purified from *M. tuberculosis* H37 Rv and covalently conjugated to tetanus toxoid and cross-reactive mutant (CRM197) diphtheria toxoid, have proven to be highly immunogenic, inducing an IgG response in rabbit and guinea pig models.¹¹

Although the gross structural features of LAM have been elucidated^{5,6,12} (Figure 1), the degree of branching of the mannan and arabinan backbone and the attachment site for the arabinan chain remain elusive. The LAM is believed to contain a lipomannan (LM) core, comprised of α -(1 \rightarrow 6) linked D-mannopyranose residues bound, via an α -glycosidic linkage, to the O-6 position of an inositol. Approximately half of these mannose residues contain an α -(1 \rightarrow 2) D-mannopyranosyl branch. An α -(1 \rightarrow 5) linked D-arabinofuranosyl chain, with periodic α -(1 \rightarrow 3) branch points, is attached to the mannan core. These arabinan branch points frequently contain further α -(1 \rightarrow 3) and α -(1 \rightarrow 5)

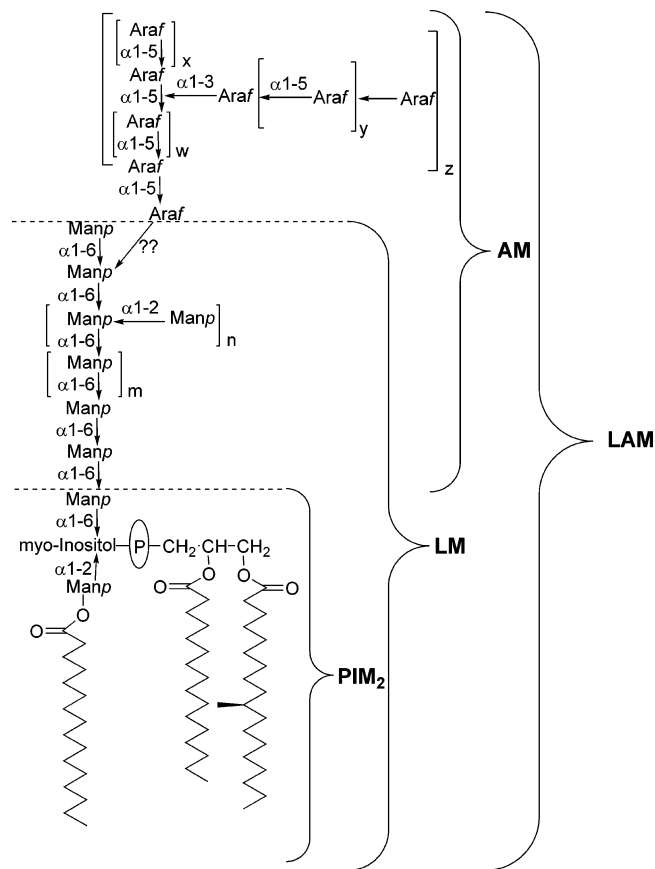

FIGURE 1. Key structural features of lipoarabinomannan (LAM) from *M. tuberculosis*.

branching. The arabinan core is usually terminated with a hexaarabinan motif containing two β -(1 \rightarrow 2) linkages that, in the case of LAMs isolated from *M. tuberculosis*, are often capped with α -(1 \rightarrow 5)-linked mono-, di-, or trimannosides. Such mannosylated LAMs are referred to as ManLAMs.

Due to their biological importance, significant effort has been made toward the synthesis of *M. tuberculosis* capsular oligosaccharides. Much of this work has concerned the synthesis of the nonreducing portion of the LAM.^{12,13} In this context, Lowary focused on the development of *p*-cresol thioglycoside methodology for the installation of the β -arabino linkage¹² and the synthesis of a protected core arabinan fragment of the LAM was accomplished using *n*-pentenylortho esters.¹⁴ The synthesis of a LM has been reported,¹⁵ although the strategy employed does not readily allow for the coupling of further arabinan motifs. The first total synthesis of phosphatidylinositol mannosides (PIM₂ and PIM₆) was reported recently.¹⁶ Despite considerable efforts in the assembly of TB oligosaccharides, the synthesis of TB arabinomannans (AMs) has not been reported.

(13) (a) Meryyala, H. B.; Hotha, S.; Gurjar, M. K. *Chem. Commun.* **1998**, 685–686. (b) Bamhaoud, T.; Sanchez, S.; Prandi, J. *Chem. Commun.* **2000**, 659–660. (c) Marotte, K.; Sanchez, S.; Bamhaoud, T.; Prandi, J. *Eur. J. Org. Chem.* **2003**, 3587–3598.

(14) (a) Lu, J.; Fraser-Reid, B. *Org. Lett.* **2004**, 6, 3051–3054. (b) Lu, J.; Fraser-Reid, B. *Chem. Commun.* **2005**, 862–864.

(15) Jayaprakash, K. N.; Lu, J.; Fraser-Reid, B. *Angew. Chem., Int. Ed.* **2005**, 44, 5894–5898.

(16) Liu, X.; Stocker, B. L.; Seeberger, P. H. *J. Am. Chem. Soc.* **2006**, 128, 3638–3648 and references cited herein.

- (3) Collins, F. M. *CRC Crit. Rev. Microbiol.* **1993**, 19, 1–16.
 (4) Jarlier, V.; Nikaïdo, H. *FEMS Microbiol. Lett.* **1994**, 123, 11–18.
 (5) (a) Brennan, P. J. *Annu. Rev. Biochem.* **1995**, 64, 29–63. (b) Vercellone, A.; Nigou, J.; Puzo, G. *Front. Biosci.* **1998**, 3, 149–163.
 (6) Chatterjee, D. *Curr. Opin. Chem. Biol.* **1997**, 1, 579–588.
 (7) Kaplan, G.; Gandhi, R. R.; Weinstein, D. E.; Levis, W. R.; Patarroyo, M. E.; Brennan, P. J.; Cohn, Z. A. *J. Immunol.* **1987**, 138, 3028–3034.
 (8) Chan, J.; Fan, X.; Hunter, S. W.; Brennan, P. J.; Bloom, B. R. *Infect. Immun.* **1991**, 59, 1755–1761.
 (9) Sibley, L. D.; Hunter, S. W.; Brennan, P. J.; Krahenbuhl, J. L. *Infect. Immun.* **1988**, 56, 1232–1236.
 (10) (a) Moreno, C.; Mehler, A.; Lamb, J. *Clin. Exp. Immunol.* **1988**, 74, 206–210. (b) Moreno, C.; Taverne, J.; Mehler, A.; Bate, C. A. W.; Brealey, R. J.; Meager, A.; Rook, G. A. W.; Playfair, J. H. L. *Clin. Exp. Immunol.* **1989**, 76, 240–245. (c) Barnes, P. F.; Chatterjee, D.; Brennan, P. J.; Rea, T. H.; Modlin, R. L. *Infect. Immun.* **1992**, 60, 1441–1446. (d) Chatterjee, D.; Roberts, A. D.; Lowell, K.; Brennan, P. J.; Orme, I. M. *Infect. Immun.* **1992**, 60, 1249–1253. (e) Adams, L. B.; Fukutomi, Y.; Krahenbuhl, J. L. *Infect. Immun.* **1993**, 61, 4173–4181.
 (11) (a) Beston, H.; Kallenius, G.; Svenson, S. B. *Vaccine* **1999**, 17, 2853–2861. (b) Hamasur, B.; Haile, M.; Pawlowski, A.; Schroder, U.; Williams, A.; Hatch, G.; Hall, G.; Marsh, P.; Kallenius, G.; Svenson, S. B. *Vaccine* **2003**, 21, 4081–4093.
 (12) (a) Lowary, T. L. *J. Carbohydr. Chem.* **2002**, 21, 691–722. (b) Gadikota, R. R.; Callam, C. S.; Appelmelk, B. J.; Lowary, T. L. *J. Carbohydr. Chem.* **2003**, 22, 459–480. (c) Ayers, J. D.; Lowary, T. L.; Morehouse, C. B.; Besra, G. S. *Bioorg. Med. Chem. Lett.* **1998**, 8, 437–442. (d) D’Souza, F. W.; Ayers, J. D.; McCarren, P. R.; Lowary, T. L. *J. Am. Chem. Soc.* **2000**, 122, 1251–1260. (e) Han, J.; Gadikota, R. R.; McCarren, P. R.; Lowary, T. L. *Carbohydr. Res.* **2003**, 338, 581–588. (f) Yin, H.; D’Souza, F. W.; Lowary, T. L. *J. Org. Chem.* **2002**, 67, 892–903. (g) D’Souza, F. W.; Lowary, T. L. *Org. Lett.* **2000**, 2, 1493–1495. (h) Gadikota, R. R.; Callam, C. S.; Appelmelk, B. J.; Lowary, T. L. *J. Carbohydr. Chem.* **2003**, 22, 149–170.

SCHEME 1. Retrosynthesis for the Target Arabinomannan Portion of LAM

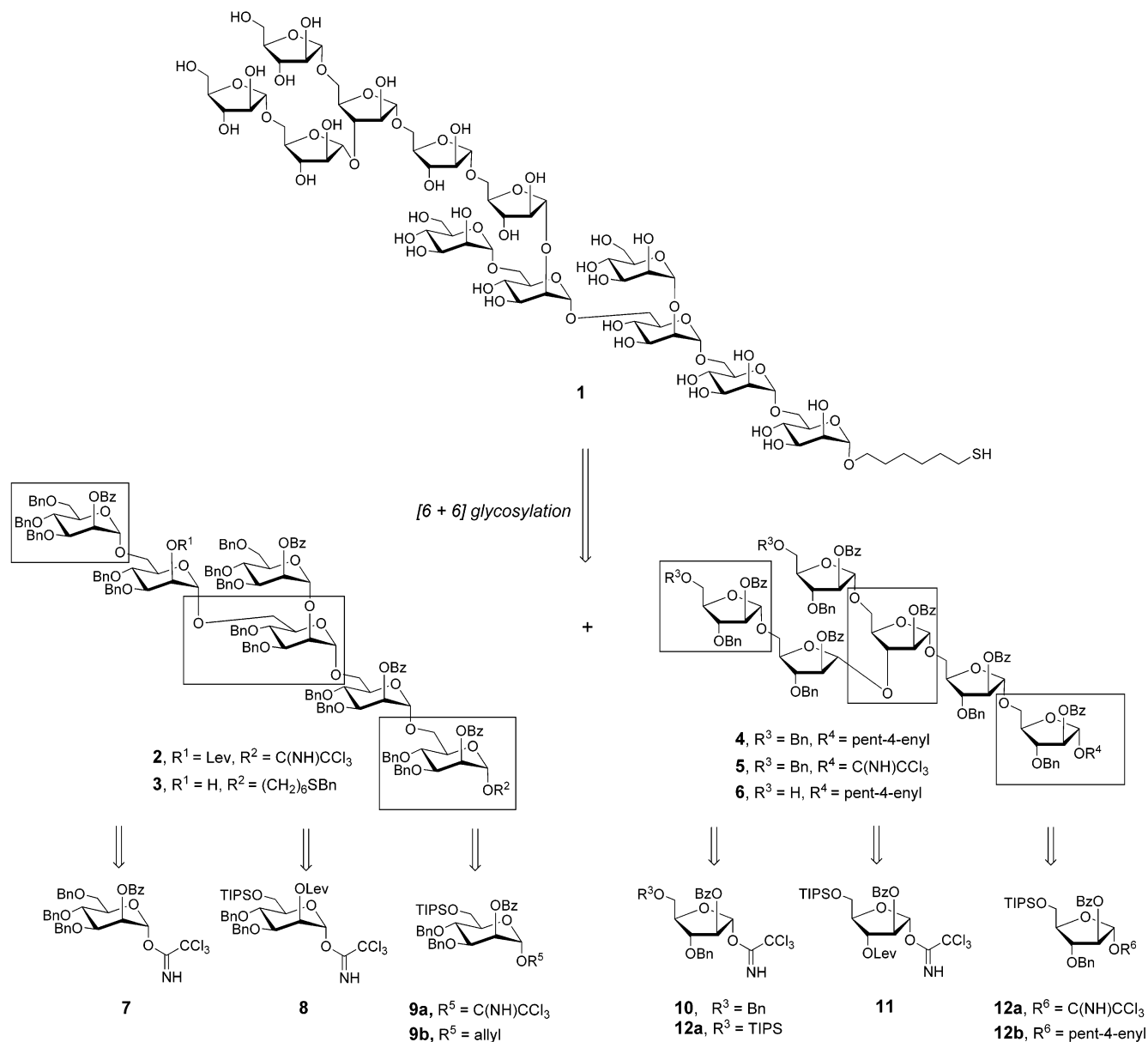

LAM exhibits a wide variety of immunomodulatory functions, yet the biological implication of the *in vitro* immunological data is not always clear.¹⁷ The synthesis of key AM and analogues thereof, and their attachment to microarrays and protein carriers for biological testing, will provide insight into the structure–activity relationship (SAR) of these compounds.

Results and Discussion

Synthetic Strategies and Target Structures. Synthesis of the AM core **1** of the LAM was envisioned to proceed via a [6 + 6] glycosylation between hexamannoside **3** and arabinan imidate **5** (Scheme 1).¹⁸ A subsequent synthesis of a more elaborate LAM would require the coupling of the mannan hexasaccharide core to an inositol pseudotrisaccharide.¹⁵ Accord-

ingly, hexamannoside **3** was synthesized from imidate **2**, rather than commencing with a thiol linker at the reducing end (R²) of the mannoside. Construction of the mannan core in turn required the use of three building blocks—mannose **7** for the terminating monosaccharide caps, **8** for the α -(1→2) and α -(1→6) branching, and **9a** for the α -(1→6) mannan backbone. All three monomers could be obtained from one common ortho ester precursor. An allyl substituent was used as a temporary protecting group for the mannan reducing end and required the incorporation of building block **9b** (R⁵ = allyl). The arabinan core **4** could again be synthesized from three building blocks—monomer **10** for the terminal arabinan caps, **11** for the α -(1→3) and α -(1→5) branching, and **12a** for the linear α -(1→5) arabinan backbone. The incorporation of a temporary pent-4-enyl substituent at the reducing end (R⁶ = pent-4-enyl) was to be achieved by incorporating **12b**. To test the possibility of elongating the arabinan core at a later date, building block **12a** was also to be incorporated at the nonreducing end of the arabinan core.

(17) Chatterjee, D.; Khoo, K.-Y. *Glycobiology* **1998**, *8*, 113–120.

(18) Although the linkage of the arabinan core to the mannan core has not been conclusively characterized, consensus favors an α -linkage at the 2 position of the arabinan. See ref 5a.

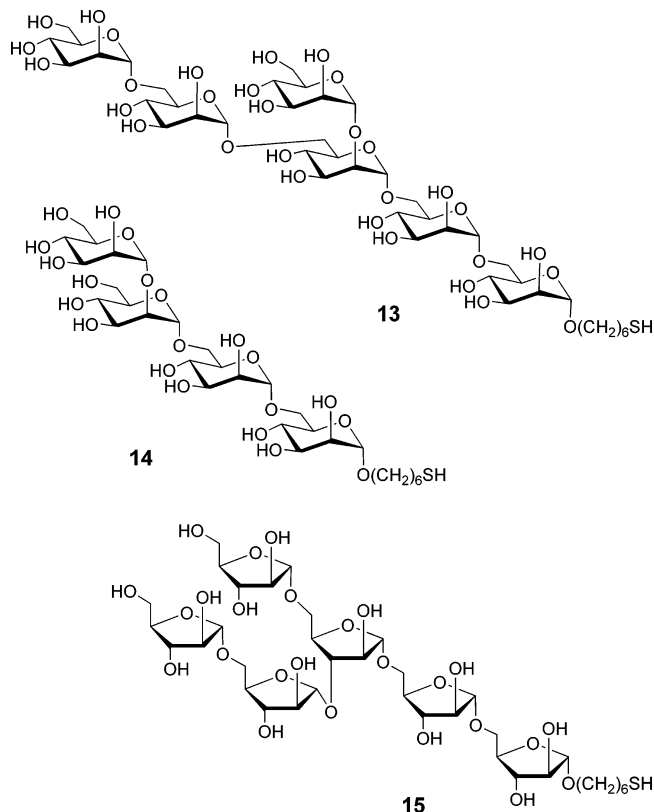

FIGURE 2. Arabinan and mannan oligosaccharides for SAR studies.

In addition to the synthesis of target AM **1**, we report herein the synthesis of a series of arabinan and mannan precursors **13–15** (Figure 2), portions of the larger AM motif. These oligosaccharides will be prepared following protocols similar to those used for the preparation of the AM. As with AM **1**, all oligosaccharides were prepared using a defined set of building blocks, thus allowing for the synthesis of further AM analogues, and the complete LAM motif, at a later date.

Synthesis of the Mannose Building Blocks. Ortho ester **17**, prepared from known glycosyl bromide **16**,¹⁹ was the common intermediate for the synthesis of all three mannosyl trichloroacetimidates. Conversion of **17** to imidate **7** proceeded smoothly following benzylation to yield ortho ester **18**, acid-catalyzed hydrolysis of the ortho ester, and installation of the anomeric trichloroacetimidate²⁰ (Scheme 2). Similarly, synthesis of imidate **9a** was readily achieved by regioselective silylation of **17**, subsequent benzylation to yield crystalline ortho ester **19b**, hydrolysis of the ortho ester, and installation of the anomeric leaving group. Starting from D-mannose, both building blocks were prepared on multigram scale in six or seven steps requiring minimal purification by column chromatography.

To maximize the convergence of our strategy, synthesis of building block **8** commenced with the glycosylation of **9a** with allyl alcohol (Scheme 3). Despite the participation of the benzoyl substituent at C-2, this glycosylation furnished **9b** as a mixture of anomers ($\alpha/\beta = 11:1$), presumably due to the increased

SCHEME 2. Synthesis of Mannose Building Blocks **7** and **9a**^a

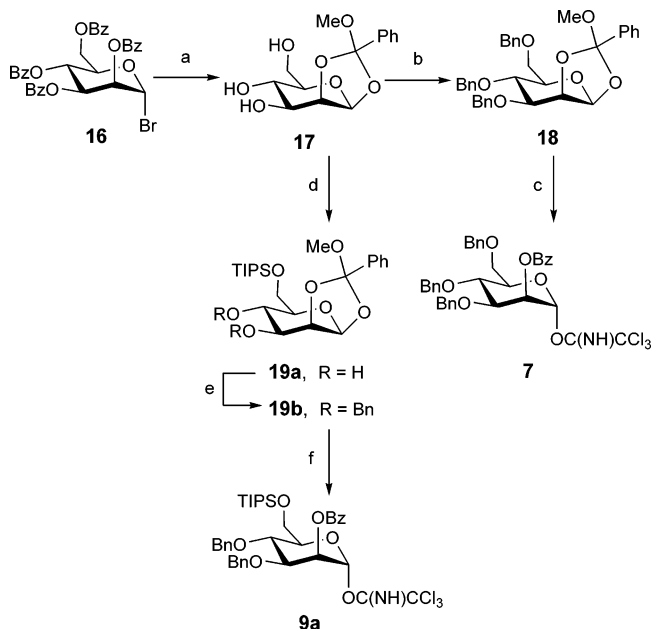

^a Reagents and conditions: (a) (i) 2,6-lutidine, MeOH, CH₂Cl₂, rt; (ii) NaOMe, MeOH/CH₂Cl₂, rt, 67% (2 steps); (b) BnBr, NaH, DMF, imidazole, rt, 94%; (c) (i) AcOH, H₂O, rt; (ii) Cl₃CCN, DBU, CH₂Cl₂, 0 °C, 78% (two steps); (d) TIPSOTf, imidazole, DMF, rt, 66%; (e) BnBr, NaH, DMF, imidazole, rt, 95%; (f) (i) AcOH, H₂O, rt; (ii) Cl₃CCN, DBU, CH₂Cl₂, 0 °C, 80% (2 steps).

SCHEME 3. Synthesis of Mannose Building Block **8**^a

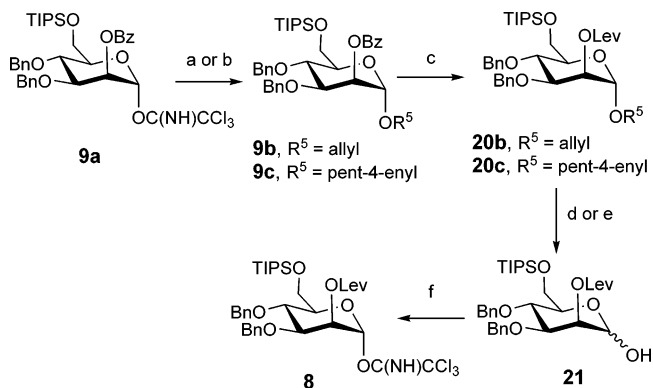

^a Reagents and conditions: (a) R⁵ = allyl: allyl alcohol, TMSOTf (cat.), CH₂Cl₂, 0 °C, $\alpha/\beta = 11:1$, 88%; (b) R⁵ = pent-4-enyl: pent-4-en-1-ol, TMSOTf (cat.), CH₂Cl₂, 0 °C, 88%; (c) (i) NaOMe, MeOH/CH₂Cl₂, rt, 99% (R⁵ = allyl), 88% (R⁵ = pent-4-enyl); (ii) LevOH, DMAP, DIPC, CH₂Cl₂, 0 °C to rt, 94% (R⁵ = allyl), 96% (R⁵ = pent-4-enyl); (d) R⁵ = allyl: Pd(OAc)₂, PPh₃, HNEt₂, MeOH, rt 78%; (e) R⁵ = pent-4-enyl: NBS, THF (aq), rt 65%; (f) Cl₃CCN, DBU, CH₂Cl₂, 0 °C, 76%.

nucleophilicity of allyl alcohol. This anomeric mixture was used directly for the synthesis of imidate **8**, though if required, the mixture of anomers can be readily separated using standard flash column chromatography. Allyl glycoside **9b** was then debenzoylated using Zemplén conditions and the levulinoyl substituent installed to give **20b** in 87% yield over two steps. Removal of the allyl moiety to allow for the installation of the imidate, however, proved more problematic. Deallylation with catalytic (10%) Pd(PPh₃)₄ and *p*-toluenesulfonic acid²¹ proceeded slowly,

(19) Ness, R. K.; Fletcher, H. G.; Hudson, C. S. *J. Am. Chem. Soc.* **1950**, *72*, 2200–2240.

(20) (a) Schmidt, R. R. *Angew. Chem., Int. Ed. Engl.* **1986**, *25*, 212–235. (b) Schmidt, R. R.; Kinzy, W. *Adv. Carbohydr. Chem. Biochem.* **1994**, *50*, 21–123. (c) Schmidt, R. R. *Front. Nat. Prod. Res.* **1996**, *1*, 20–54. (d) Schmidt, R. R. *Pure Appl. Chem.* **1989**, *61*, 1257–1270.

(21) Opatz, T.; Kunz, H. *Tetrahedron Lett.* **2000**, *41*, 10185–10188.

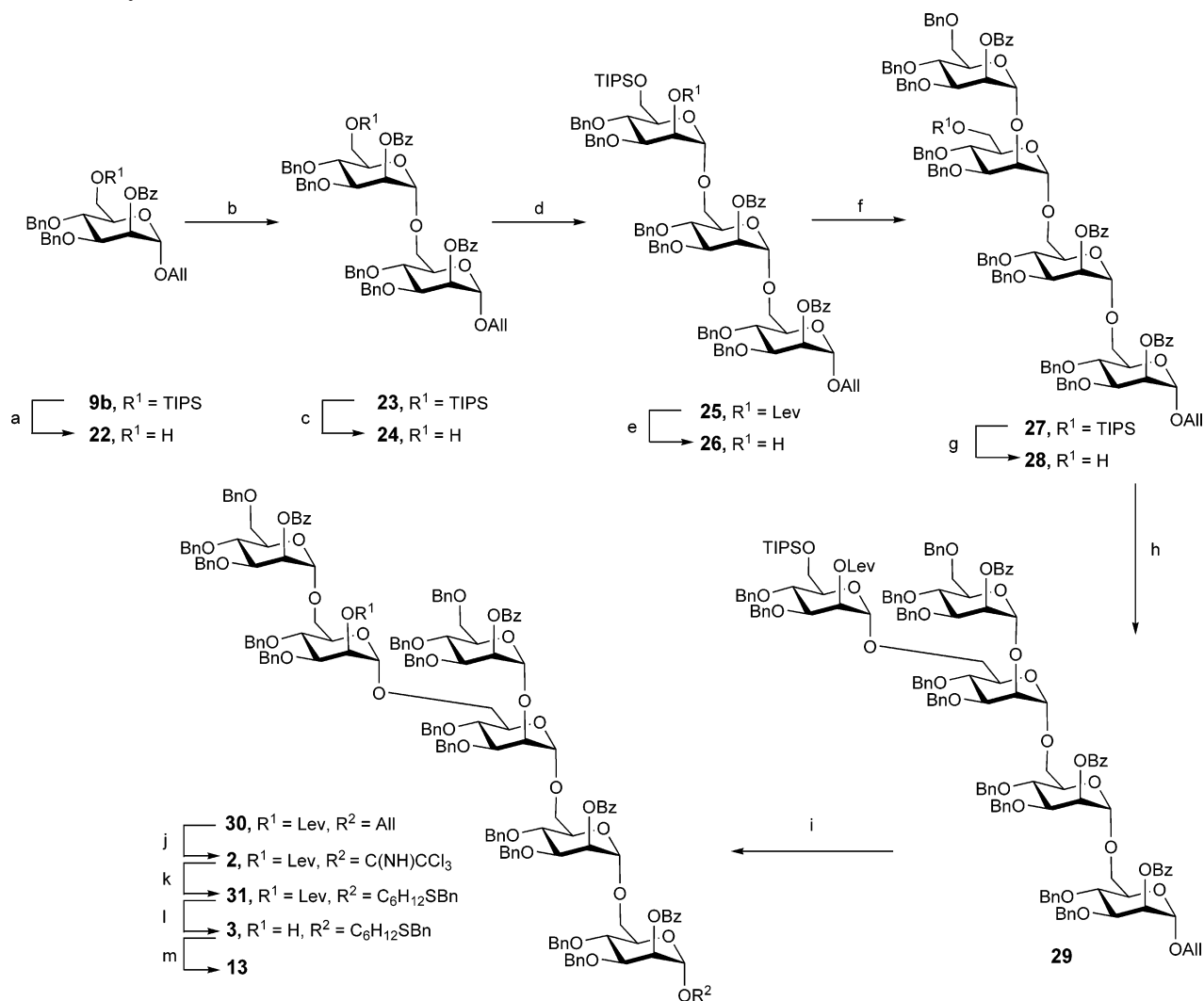
SCHEME 4. Synthesis of Mannan Hexasaccharide **13**^a

^a Reagents and conditions: (a) TBAF, THF, rt, 82%; (b) **9a**, TMSOTf (cat.), CH₂Cl₂, 0 °C, 92%; (c) AcCl in MeOH/CH₂Cl₂, rt, 96%; (d) **8**, TMSOTf (cat.), CH₂Cl₂, 0 °C, 80%; (e) H₂NNH₂·H₂O, pyridine, AcOH, CH₂Cl₂, rt, 92%; (f) **7**, TMSOTf (cat.), CH₂Cl₂, 0 °C, 90%; (g) AcCl in MeOH/CH₂Cl₂, rt, 90%; (h) **8**, TMSOTf (cat.), CH₂Cl₂, 0 °C, 85%; (i) (i) AcCl in MeOH/CH₂Cl₂, rt, 84%; (ii) **7**, TMSOTf (cat.), CH₂Cl₂, 0 °C, 92%; (j) (i) {Ir(COD)[PCH₃(C₆H₅)₂]}PF₆ (cat.), THF, rt; (ii) I₂, THF/H₂O, rt; (iii) Cl₃CCN, DBU, CH₂Cl₂, 0 °C, 81% (3 steps); (k) (i) HO(CH₂)₆SBn, TMSOTf (cat.), CH₂Cl₂, 0 °C; (ii) pyridine, Ac₂O, rt, 89% (2 steps); (l) H₂NNH₂·H₂O, pyridine, AcOH, rt, 96%; (m) Na, NH₃ (l), THF, -78 °C, 92%.

with competing decomposition of the allyl glycoside. The use of PdCl₂ under buffered conditions (AcOH, NaOAc)²² was unreliable as it furnished lactol **21** in yields from 40 to 70% along with varying amounts of the corresponding Wacker oxidation product. To prevent formation of the oxidation byproduct, anhydrous conditions, requiring the use of catalytic PdCl₂ in MeOH,²³ were explored. Unfortunately, due to the in situ generation of HCl, desilylation was observed even under dilute (15 μM) conditions. We then turned our attention to the synthesis of the pentenyl derivative **9c**²⁴ in anticipation of NBS-mediated cleavage of the pentenyl moiety.²⁵ Though successful, the halohydrin byproduct was also observed resulting in a

suboptimal (65%) yield of lactol **21**. Returning to the allyl glycoside **9b**, attempts were then made at cleaving the allyl moiety via a two-step protocol involving the isomerization of the allyl moiety to the enol ether followed by oxidative cleavage to the lactol. Wilkinson's catalyst²⁶ (Ph₃P)₃RhCl gave poor (approximately 30%) yield for the isomerization of the allyl moiety; however, the iridium catalyst²⁷ {Ir(COD)[PCH₃(C₆H₅)₂]}PF₆ proved more viable. Allyl isomerization followed by oxidative cleavage with either I₂ in THF/H₂O,²⁸ or NIS in 1% aqueous THF,²⁹ produced lactol **21** in 70–75% yield. This was an encouraging result. Nevertheless, the strictly anhydrous

(22) Smith, A. B.; Rivero, R. A.; Hale, K. J.; Vaccare, H. A. *J. Am. Chem. Soc.* **1991**, *113*, 2092–2112.

(23) Ogawa, T.; Kaburagi, T. *Carbohydr. Res.* **1982**, *110*, 12–15.

(24) **9c** was prepared from **9a** using a protocol similar to that for the synthesis of **9b** (see Scheme 3).

(25) Wilson, B. G.; Fraser-Reid, B. *J. Org. Chem.* **1995**, *60*, 317–320.

(26) Dufour, M.; Gramain, J.-C.; Husson, H.-P.; Sinibaldi, M.-E.; Troin, Y. *Tetrahedron Lett.* **1989**, *30*, 3429–3432.

(27) Oltyoort, J. J.; Van Boeckel, C. A. A.; De Koning, J. H.; Van Boom, J. H. *Synthesis* **1981**, 305–308.

(28) Timmer, M. S. M.; Codée, J. D. C.; Overkleef, H. S.; Van Boom, J. H.; Van der Marel, G. A. *Synlett* **2004**, 2155–2158.

(29) Halkes, K. M. Slaghek, T. M.; Vermeer, H. J.; Kamerling, J. P.; Vliegthart, J. F. G. *Tetrahedron Lett.* **1995**, *36*, 6137–6140.

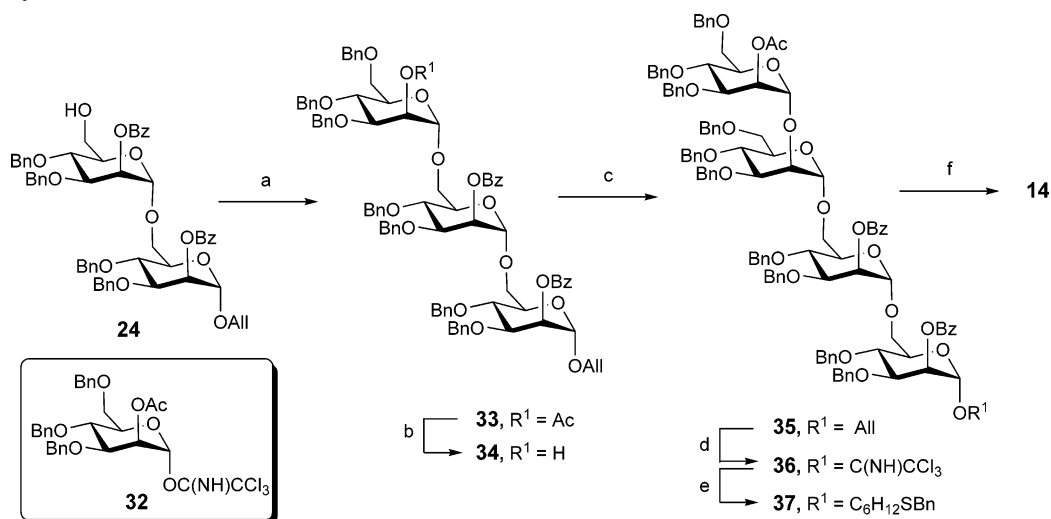
SCHEME 5. Synthesis of Mannan Tetrasaccharide 14^a

^a Reagents and conditions: (a) **32**, TMSOTf (cat.), CH₂Cl₂, 0 °C, 98%; (b) AcCl in MeOH/CH₂Cl₂, rt, 93%; (c) **32**, TMSOTf (cat.), CH₂Cl₂, 0 °C, 83%; (d) (i) {Ir(COD)[PCH₃(C₆H₅)₂]₂}PF₆ (cat.), THF, rt; (ii) I₂, THF/H₂O, rt; (iii) Cl₃CCN, DBU, CH₂Cl₂, 0 °C, 81% (3 steps); (e) (i) HO(CH₂)₆SbN, TMSOTf (cat.), CH₂Cl₂, 0 °C; (ii) pyridine, AcOH, rt, 93% (2 steps); (f) Na, NH₃ (l), THF, -78 °C, 93%.

and inert conditions required during the isomerization³⁰ prompted us to identify a less demanding protocol. Fortunately, an in situ generated Pd(PPh₃)₄-catalyzed deallylation under basic conditions³¹ was amenable to our substrate and gave lactol **21** in 78% yield. With a suitable deallylation protocol established, lactol **21** was transformed to imidate **8** to complete the synthesis of the mannose building block.

Assembly of the Mannan Hexasaccharide Core 13 and the Tetrasaccharide Intermediate 14. Synthesis of the core mannan hexasaccharide (Scheme 4) commenced with glycoside **9b** that was desilylated with TBAF to give alcohol **22**. Union of **22** and imidate **9a** using standard TMSOTf-catalyzed glycosylation methodology furnished disaccharide **23** in 75% over two steps. Desilylation under mildly acidic conditions, using acetyl chloride in MeOH/CH₂Cl₂ rather than TBAF, proved optimal for the formation of disaccharide **24**. Disaccharide **24** was then coupled, with complete α-selectivity, to monomer **8** to install the branching point in the trisaccharide mannan chain **2**. Delevulinoylation of **25**, using hydrazine monohydrate in buffered conditions, also occurred smoothly and in excellent yield to give trisaccharide **26**. Installation of the α-(1→2) linked mannose cap was achieved by glycosylation with **7** to give tetrasaccharide **27** in 90% yield. Tetrasaccharide **27** was desilylated under mildly acidic conditions to give alcohol **28**, which was subsequently coupled to levulinoyl imidate **8** for installation of the second branch point in the mannan core. Again, elongation of the α-(1→6) linked mannan backbone by desilylation of pentasaccharide **29** followed by glycosylation with imidate **9a** proceeded smoothly with complete α-selectivity to give mannan hexasaccharide **30** in 77% yield over two steps.

To allow for the attachment of target AM **1** (or hexasaccharide mannan precursor **3**) to a microarray or protein carrier, the allyl moiety of **30** had to be cleaved. In the case of allyl glycoside **30**, it was found that isomerization of the allyl moiety using {Ir(COD)[PCH₃(C₆H₅)₂]₂}PF₆, followed by oxidative cleavage

with I₂ in THF/H₂O, produced the corresponding lactol in excellent (92%) yield. The lactol was then converted to imidate **2** using DBU and Cl₃CCN. Glycosylation of 6-(benzylthio)hexan-1-ol with imidate **2** followed. Although this glycosylation occurred readily, problems were encountered with separating the excess linker from hexasaccharide **31**. Though differing in *R_f* values, hexasaccharide **31** and the linker had a propensity to coelute during silica gel column chromatography. This separation problem could not be solved even when the excess of linker was reduced to 1.5 equiv and several solvent conditions for purification by column chromatography were tried. To circumvent this problem, acetylation of the linker in the crude reaction mixture was performed, which in turn allowed for the purification of hexasaccharide **31** by flash chromatography. The levulinoyl substituent of hexasaccharide **31** was then removed, using hydrazine monohydrate in neat pyridine/AcOH, to give alcohol **3**, ready for coupling to the arabinan core **5**, in a respectable 84% yield over three steps. In accordance with our objective to prepare intermediate arabinan and mannan motifs for SAR studies, mannan hexasaccharide **3** was also deprotected using Birch conditions to afford **13**, exclusively as the disulfide dimer, in 92% yield.

Synthesis of the mannan tetrasaccharide intermediate **14** (Scheme 5) commenced with the glycosylation of disaccharide **24** using building block **32**³² to give trisaccharide **33** in excellent yield. Though this strategy required the incorporation of an additional building block, the readily synthesized acetylated building block **32** was considered to be the most appropriate choice.³³ Trisaccharide **33** was then selectively deprotected to give alcohol **34** in 93% yield and the final monosaccharide **32** incorporated to furnish tetrasaccharide core **35**. The allyl moiety was then cleaved, using {Ir(COD)[PCH₃(C₆H₅)₂]₂}PF₆-catalyzed isomerization followed by I₂-mediated cleavage, and the trichlo-

(30) For optimal yields, requiring a lower catalytic loading, the reaction should be performed in THF freshly distilled from sodium and benzophenone that is subsequently degassed for 30 min.

(31) Harvey, J. E.; Raw, S. A.; Taylor, R. J. *Org. Lett.* **2004**, *6*, 2611–2614.

(32) (a) Fischer, E.; Oetker, R. *Ber. Dtsch. Chem. Ges.* **1913**, *46*, 4029–4040. (b) Kaur, K. J.; Hindsgaul, O. *Carbohydr. Res.* **1992**, *226*, 219–231. (c) Borén, H. B.; Ekborg, G.; Ekland, K. *Acta Chim. Scand.* **1973**, *27*, 2639–2644. (d) Mayer, T. G.; Schmidt, R. R. *Eur. J. Org. Chem.* **1999**, 1153–1166.

(33) Imidate **32** is easier to prepare than imidate **8** and has the protecting group pattern to allow for the installation of the second α-(1→2) linkage.

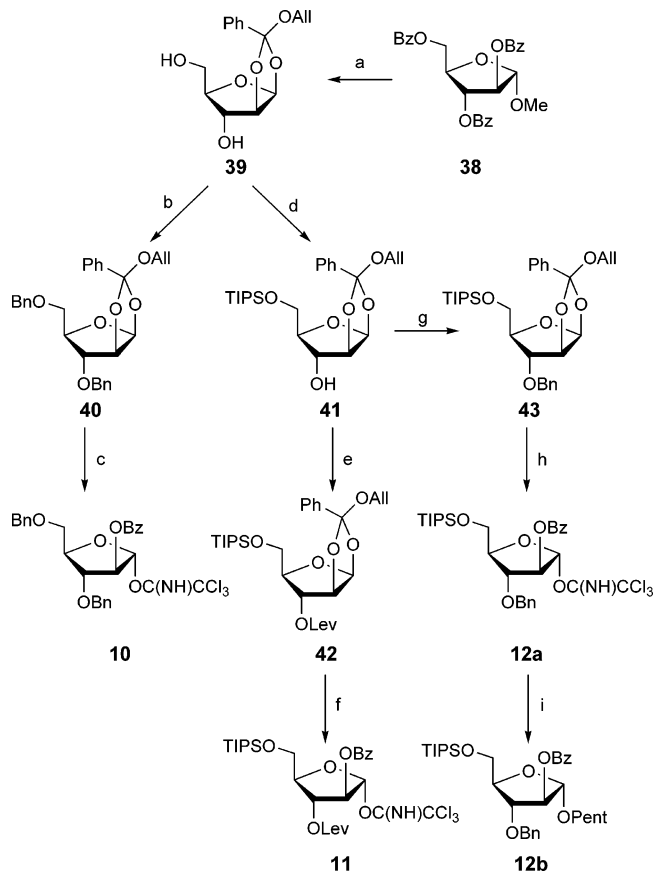
SCHEME 6. Synthesis of Arabinose Building Blocks 10–12^a

^a Reagents and conditions: (a) (i) Cl_2CHOMe , SnCl_4 , CH_2Cl_2 , rt; (ii) allyl alcohol, 2,6-lutidine, CH_2Cl_2 , rt; (iii) NaOMe , MeOH , CH_2Cl_2 , rt, 79% (3 steps); (b) BnBr , NaH , DMF , 0°C to rt, 95%; (c) (i) $p\text{-TsOH}\cdot\text{H}_2\text{O}$, 1,2-dimethoxyethane, H_2O , 0°C to rt; (ii) DBU , Cl_3CCN , CH_2Cl_2 , 0°C , 70% (2 steps); (d) TIPSO , imidazole, DMF , 0°C to rt, 76%; (e) LevOH , DMAP , DIPC , CH_2Cl_2 , rt, quant; (f) (i) $p\text{-TsOH}\cdot\text{H}_2\text{O}$, 1,2-dimethoxyethane, H_2O , 0°C to rt, 99%; (ii) DBU , Cl_3CCN , CH_2Cl_2 , 0°C , 88%; (g) NaH , BnBr , DMF , rt, 12 h; (h) (i) $p\text{-TsOH}\cdot\text{H}_2\text{O}$, 1,2-dimethoxyethane, H_2O , 0°C to rt, 86% (2 steps); (ii) DBU , Cl_3CCN , CH_2Cl_2 , 0°C , 98%; (i) pent-4-en-1-ol, TMSOTf (cat.), CH_2Cl_2 , -40 to -30°C , 97%.

roacetimidate moiety installed to give imidate 36 in 81% over three steps. Again, attempts to remove the excess thiol linker, following glycosylation with 6-(benzylthio)hexan-1-ol, were problematic, and purification of 37 was only possible after the excess linker was acetylated. Finally, global deprotection under Birch conditions gave 14, again as the disulfide dimer, in excellent (93%) yield.

Synthesis of the Arabinose Building Blocks. All required arabinofuranoside imidates were synthesized on large scale from D-arabinose in eight or nine steps (Scheme 6). Ortho ester 39, prepared in three steps from crystalline methyl 2,3,5-tri-*O*-benzoyl- α -D-arabinofuranoside (38),³⁴ was used as the key intermediate for the synthesis of all three building blocks. Conversion of 39 to imidate 10 proceeded smoothly via bis-benzylation to furnish ortho ester 40, acid-induced hydrolysis of the ortho ester, and installation of the anomeric imidate. Alternatively, regioselective silylation of the primary hydroxyl group of 39 gave ortho ester 41 that was used as the common intermediate for the synthesis of imidates 11 and 12a. Synthesis

of 11 was readily achieved by installation of the levulinoyl substituent to yield ortho ester 42 prior to hydrolysis of the ortho ester and installation of the anomeric imidate. Similarly, 12a was obtained by benzylation of 41 to give ortho ester 43, hydrolysis of the ortho ester and conversion of the lactol to the anomeric imidate.

During the construction of the oligoarabinans, a temporary protecting group for the reducing end of the arabinan chain was required. Literature precedence¹⁴ prompted us to select a pentenyl moiety for this purpose, in turn necessitating the synthesis of building block 12b. Pentenyl glycoside 12b was readily prepared following TMSOTf -catalyzed glycosylation of 12a with pent-4-en-1-ol at -40 to -30°C .

Assembly of the Arabinan Hexasaccharides. The assembly of the arabinan hexasaccharide core commenced with the desilylation of pentenyl glycoside 12b, again under mildly acidic conditions, followed by coupling to imidate 12a under standard TMSOTf activation (Scheme 7). Subsequent desilylation afforded known disaccharide 45^{14a} in 79% yield over three steps. Disaccharide 45 was then coupled to imidate 11 in the presence of TMSOTf to install the branching point. Although this glycosylation proceeded smoothly with complete α -selectivity, problems were encountered in the separation of trisaccharide 46 from the byproduct trichloroacetamide. Several solvent conditions for purification by flash column chromatography, as well as purification by size-exclusion chromatography, were screened with limited success. Consequently, the mixture was treated directly with hydrazine monohydrate under buffered conditions to remove the levulinoyl group. This process allowed for successful purification and afforded the desired trisaccharide 47 in 82% yield over two steps. Installation of the α -(1 \rightarrow 3) branch was then achieved by glycosylation of 47 with imidate 12a under TMSOTf activation to give tetrasaccharide 48 with complete α -selectivity. Removal of both silyl ethers under mildly acidic conditions provided key tetrasaccharide 49 in 87% yield. Subsequent capping with two equivalents of 10 in the presence of TMSOTf occurred readily, with complete α -selectivity, to give the desired arabinan hexasaccharide 4 in 92% yield. To test the possibility of elongating the arabinan core at a later date, hexasaccharide 6, containing two unprotected primary hydroxyl groups, was also synthesized. Thus, bis-glycosylation of tetrasaccharide 49 with imidate 12a under TMSOTf activation, followed by removal of both silyl ethers, gave the desired hexasaccharide 6 in 89% yield over two steps.

Pentenyl glycoside 4 needed to be transformed to the anomeric imidate 5 to allow for the attachment of the arabinan core to the mannan hexasaccharide precursor 3 or to the thiol linker. Cleavage of the pentenyl moiety by treatment with NBS in aqueous acetonitrile^{25,35} produced the desired lactol, though varying amounts of the halohydrin byproduct were also observed resulting in an acceptable, though variable, yield of the lactol. The mixture was directly treated with trichloroacetonitrile and DBU to furnish imidate 5 in 55–72% yield over two steps.

Surprisingly, the subsequent installation of the 6-(benzylthio)-hexan-1-ol linker to give intermediate 50 was somewhat problematic. Glycosylations with imidates 10, 11, and 12a typically proceeded smoothly at -40 to -30°C with complete α -selectivity, yet in the case of imidate 5, elevated temperatures

(35) The use of NBS for the pentenyl removal is preferred to the use of NIS . Traces of iodine were always present in the lactol if the reaction is performed with NIS , leading to incomplete formation of the imidate or decomposition of the starting material.

(34) Callam, C. S.; Lowary, T. L. *J. Chem. Educ.* **2001**, *78*, 73–74.

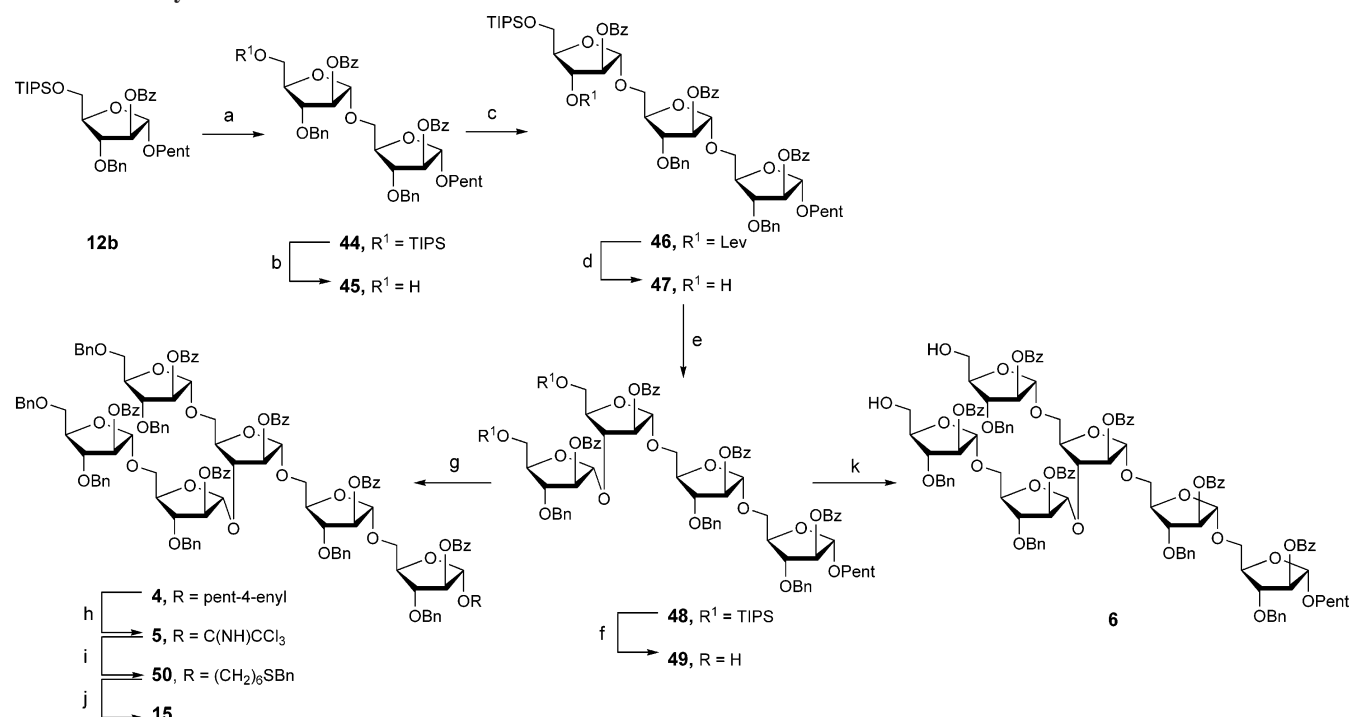
SCHEME 7. Synthesis of the Arabinan Hexasaccharides^a

^a Reagents and conditions: (a) (i) AcCl in MeOH/CH₂Cl₂, 0 °C, 96%; (ii) **12a**, TMSOTf (cat.), CH₂Cl₂, -40 to -30 °C, 94%; (b) AcCl in MeOH/CH₂Cl₂, 0 °C, 92%; (c) **11**, TMSOTf (cat.), CH₂Cl₂, -40 to -30 °C; (d) H₂NNH₂·H₂O, pyridine, AcOH, CH₂Cl₂, rt, 82% (2 steps); (e) **12a**, TMSOTf (cat.), CH₂Cl₂, -40 to -30 °C, 87%; (f) AcCl in MeOH/CH₂Cl₂, 0 °C to rt, 87%; (g) **10**, TMSOTf (cat.), CH₂Cl₂, -40 to -30 °C, 92%; (h) (i) NBS, MeCN, H₂O, rt; (ii) DBU, Cl₃CCN, CH₂Cl₂, 0 °C, 72% (2 steps); (i) HO(CH₂)₆SBn, TMSOTf (cat.), CH₂Cl₂, 0 °C; (ii) Ac₂O, pyridine, rt, 78% (2 steps, α/β ≈ 12:1); (j) Na, NH₃ (l), THF, -78 °C, 37%; (k) (i) **12a**, TMSOTf (cat.), CH₂Cl₂, -40 to -30 °C, 96%; (ii) AcCl in MeOH/CH₂Cl₂, 0 °C to rt, 93%.

(-20 to 0 °C) were necessary to achieve complete conversion. Coupling of **5** to the thiol linker proceeded in 78% yield under TMSOTf activation at -20 to -10 °C, albeit with lower α-selectivity (α/β ≈ 12:1). Attempts were made to improve this selectivity, though all solvent and temperature combinations resulted in similar ratios.³⁶ After acetylation of the reaction mixture, to allow for the removal of excess linker, it was possible to separate the anomers, and α-**50** was isolated in 66% yield. Finally, global deprotection of the hexasaccharide under Birch conditions provided **15** exclusively as the disulfide linked dimer in 37% yield.

Synthesis of the Arabinomannan Dodecasaccharide. Synthesis of arabinomannan **1** was envisioned to occur via a [6 + 6] glycosylation strategy using glycosylating agent **5** and acceptor **3** (Scheme 8). First attempts to couple both fragments under TMSOTf activation at -40 to -30 °C failed owing to the poor reactivity of **5** at lower temperatures. Under these conditions acceptor **3** and the hydrolyzed imidate were recovered after workup. A change in the reaction conditions to TBSOTf activation at 0 °C in diethyl ether,³⁷ however, allowed for the successful coupling of **5** with **3** to afford dodecasaccharide **51** in 70% yield exclusively as the α-anomer. The structure of **51** was analyzed by ¹H NMR and ¹³C NMR spectroscopy, as well as high-resolution MALDI mass spectrometry. Though the anomeric proton of the newly formed glycosidic linkage was difficult to assign, in the ¹H NMR spectrum all anomeric signals showed coupling constants of less than 2 Hz. In the ¹³C NMR

spectrum, all anomeric arabinose signals were between 105.3 and 106.7 ppm. These data are indicative of the presence of α-linkages only^{12f,38}—as was anticipated due to the presence of a C-2 benzoyl participating group on imidate **5**.

In an attempt to improve our modest yield during the global deprotection of arabinan **50**, global deprotection of **51** was achieved using a two-step protocol. Dodecasaccharide **51** was first debenzoylated under basic conditions (NaOMe), and the resulting polyol was subjected to Birch conditions to give target **1** as the disulfide-linked dimer in 52% yield.

Further Elongation of the AM Core. LAM oligosaccharides are often capped with α-(1→2)-linked mono-, di- or trimannosides at the arabinan termini, with *M. tuberculosis* frequently capped with a dimannoside.^{5b,39} Thus, we explored the further elongation of the arabinan chains with dimannan caps.⁴⁰ Initial attempts were made at bis-glycosylating hexasaccharide **6** with 2 equiv of **32** by TMSOTf activation at 0 °C. This transformation resulted in a mixture of the corresponding hepta- (minor) and octasaccharide (major product) along with varying amounts of different di- and trisaccharides.⁴¹ These byproducts were the result of an acid-induced fragmentation of the hexaarabinan core that presumably occurs at elevated temperatures due to the Lewis

(38) Mizutani, K.; Kasai, R.; Nakamura, M.; Tanaka, O.; Matsuura, H. *Carbohydr. Res.* **1989**, *185*, 27–38.

(39) Chatterjee, D.; Lowell, K.; Rivoire, B.; McNeil, M. R.; Brennan, P. J. *J. Biol. Chem.* **1992**, *267*, 6234–6249.

(40) Though most arabinan caps contain a challenging β-(1→2) arabinan linkage in the hexaarabinan cap, we first wanted to test the overall plausibility of attaching a mannose cap. Many of the elegant strategies, most notably those developed by Lowary and co-workers, could be used at a later date to install the appropriate β-linkage; see ref 12. The terminal regions of the linear AM chain however, have been shown to contain α-linkages only (for example, see ref 5a).

(36) Similar α/β-ratios ranging from 93:7 to 97:3 were obtained in the glycosylation of imidate **12a** with the linker [HO(CH₂)₆SBn].

(37) These conditions have been successfully applied to the coupling of larger oligoarabinan fragments ([4 + 4 + 4] coupling). See ref 14b.

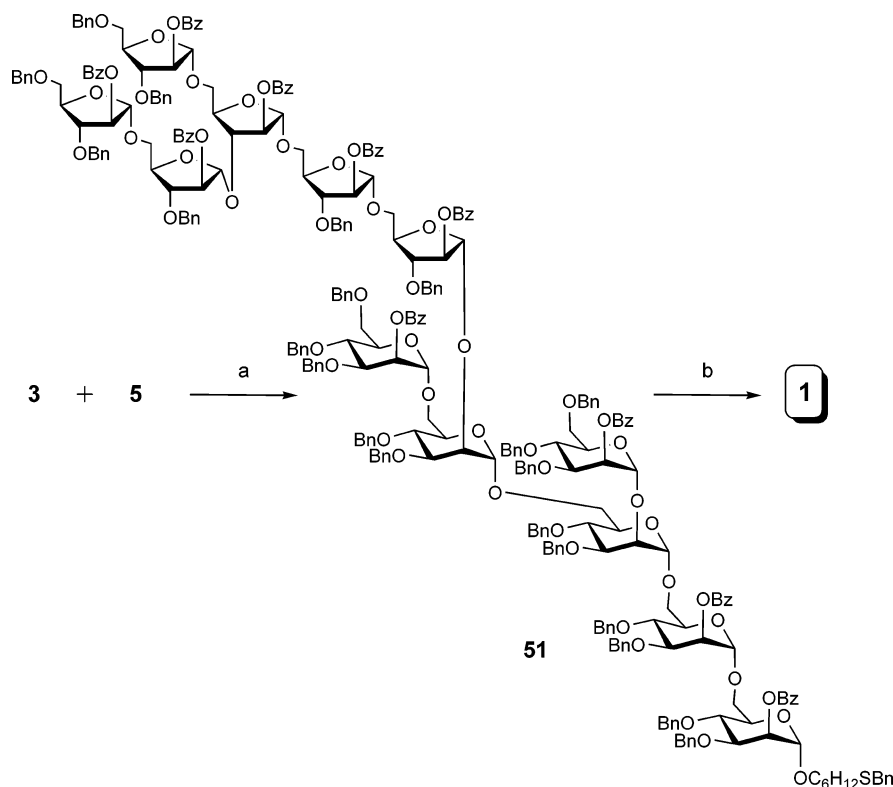
SCHEME 8. Synthesis of Dodecasaccharide 1^a

^a Reagents and conditions: (a) TBSOTf (cat.), Et₂O, 0 °C, 70%; (b) (i) NaOMe, MeOH, CH₂Cl₂, rt; (ii) Na, NH₃ (l), THF, -78 °C, 52% (2 steps).

acidity of TMSOTf. To circumvent this problem, less acidic TBSOTf was used as the activator and the desired octasaccharide was obtained in greater than 85% yield, though minor impurities were observed. For the attachment of the subsequent mannose units, the acetates had to be selectively removed. In addition, it was hoped that deacetylation would facilitate the subsequent removal of any impurities. Unfortunately, deprotection under mildly acidic and highly dilute conditions proceeded very slowly,⁴² and further addition of acetyl chloride gave only a complex mixture of products.

Consequently, this strategy was abandoned and the incorporation of a temporary levulinoyl protecting group was pursued. Imidate **52** (Scheme 9), synthesized from **32**,⁴³ was coupled to hexasaccharide **6** to provide the desired octasaccharide as the major product (approximately 70–75% yield) along with the corresponding heptasaccharide. The separation of the octa- and heptasaccharides proved difficult.⁴⁴ Silylation of the mixture

(41) The following compounds have been isolated as byproducts or detected by MS analysis:

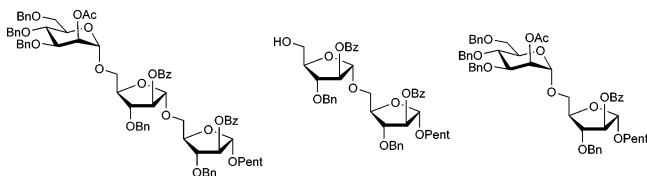

(42) Even after 3 days at room temperature starting material was still present in the reaction mixture.

(43) Similar to the synthesis of imidate **8**, imidate **52** was prepared via glycosylation of **32** with allyl alcohol (90%, $\alpha/\beta = 94/6$), removal of the acetate (99%) and protection with levulinic acid (92%, $\alpha/\beta = 94/6$), removal of the allyl group using catalytic PdCl₂ in MeOH (84%), and installation of the imidate (85%).

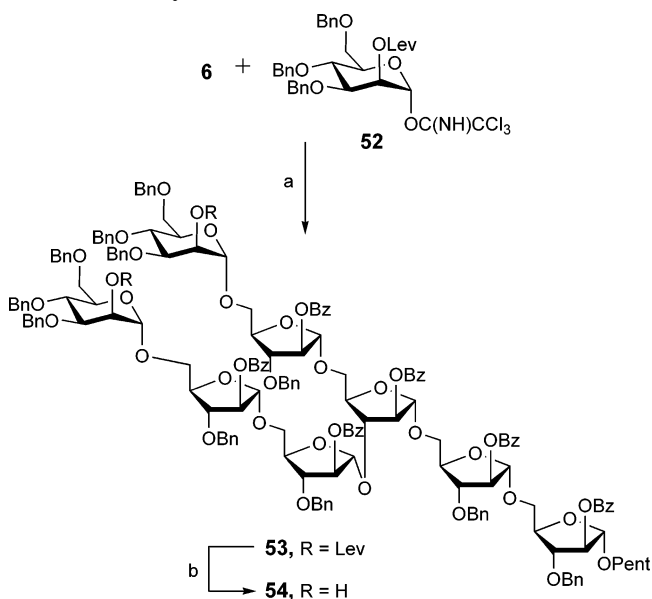
SCHEME 9. Synthesis of Mannoarabinans^a

^a Reagents and conditions: (a) (i) TBSOTf (cat.), Et₂O, 0 °C; (ii) TIPSCl, imidazole, DMF, rt, 30% (2 steps); (b) H₂NNH₂·H₂O, pyridine, AcOH, CH₂Cl₂, rt, 80%.

with TIPSCl and imidazole facilitated the separation of both compounds by flash column chromatography, but also led to degradation, as observed by TLC analysis. Consequently octasaccharide **53** was isolated in only 30% yield over two steps.

(44) No complete separation was achieved using flash column chromatography or size-exclusion chromatography.

Removal of the levulinoyl groups proceeded smoothly upon exposure to hydrazine monohydrate in buffered conditions to give octasaccharide **54** in 80% yield. Further mannosylation of **54** proved even more strenuous, leading to a complex mixture of products in which only trace amounts of the desired decasaccharide were observed, as indicated by mass spectrometry analysis.

Conclusion

Here we report the first total synthesis of an arabinomannan oligosaccharide from *M. tuberculosis* as well as a series of related arabinan and mannan oligosaccharides. Our flexible synthetic strategy involves late-stage couplings and modifications, to enable ready access to several different LAM fragments for SAR studies. Synthesis of target oligosaccharide **1** involved the preparation of hexamannan **3** and hexaarabinan **5**. Both intermediates were prepared in excellent yield and stereoselectivity using three different mannose and arabinose building blocks. Union of arabinan **5** to mannan **3**, the first reported example of the coupling of an arabinan imidate to an oligomannan core, proceeded smoothly via a [6 + 6] glycosylation to afford dodecasaccharide **51** in excellent yield. Incorporation of a thiol linker at the reducing end of the oligosaccharide allows for the easy conjugation of the compounds to carrier proteins or microarrays. In our laboratory, microarrays containing the synthetic oligomers are currently used to screen TB antibodies.

Future work will investigate the elongation of the arabinan core and the synthesis of mannan-capped arabinomannans. Later, the β -arabinoside linkage will be included. These molecules will serve as molecular tools for biological studies and will eventually help to find a carbohydrate antigen for vaccinations against TB.

Experimental Section

Allyl 2-O-Benzoyl-3,4-di-O-benzyl- α -D-mannopyranoside (22). To a solution of allyl glycoside **9b** (6.60 g, 9.90 mmol) in THF (150 mL) at 0 °C was added TBAF (20.1 mL of a 1 M solution in THF, 20.1 mmol) and the solution stirred overnight with gradual warming to room temperature. The solution was then extracted with EtOAc (2 \times 150 mL), the combined organic extracts were washed once with water and once with brine and dried over MgSO₄, and the solvents were removed under reduced pressure. The resulting oil was purified by gradient flash silica gel column chromatography (hexanes/EtOAc, 3:1 to 2:1) to give **22** (4.06 g, 82%) as a colorless oil. Spectral data matched that previously reported.⁴⁵

Allyl 6-O-(2-O-Benzoyl-3,4-di-O-benzyl-6-O-triisopropylsilyl- α -D-mannopyranosyl)-2-O-benzoyl-3,4-di-O-benzyl- α -D-mannopyranoside (23). Alcohol **22** (2.67 g, 5.30 mmol) and imidate **9a** (4.46 g, 5.83 mmol) were combined and coevaporated three times with toluene before being placed under nitrogen and dissolved in CH₂Cl₂ (65 mL). The solution was then cooled to 0 °C, TMSOTf (96 μ L, 0.53 mmol) added dropwise, and the solution stirred for 30 min before being quenched by the addition of NEt₃ (200 μ L). The solvent was removed under reduced pressure and the residue purified by flash silica gel column chromatography (hexanes/EtOAc, 10:1) to give **23** (5.75 g, 98%) as a colorless oil. R_f = 0.20 (hexanes/EtOAc, 10:1). $[\alpha]_D^{25}$ = +8.0 (*c* 0.15, CHCl₃). ¹H NMR (CDCl₃, 300 MHz): δ 8.15–8.11 (m, 4H), 7.61–7.59 (m, 1H), 7.59–7.42 (m, 5H), 7.34–7.16 (m, 20H), 5.90 (ddt, *J* = 17.1, 10.5, 5.3 Hz, 1H), 5.96–5.83 (m, 1H), 5.68 (dd, *J* = 1.8, 3.0 Hz, 1H), 5.30 (dq, *J* = 17.1, 1.5 Hz, 1H), 5.20 (dq, *J* = 10.5, 1.5 Hz, 1H), 5.06 (d, *J* = 1.5 Hz, 1H), 4.98 (d, *J* = 1.8 Hz, 1H), 4.90 (d, *J* = 10.8 Hz,

1H), 4.90 (d, *J* = 11.4 Hz, 1H), 4.84 (d, *J* = 11.1 Hz, 1H), 4.77 (d, *J* = 11.4 Hz, 1H), 4.66 (d, *J* = 10.8 Hz, 1H), 4.57 (d, *J* = 11.1 Hz, 1H), 4.52 (d, *J* = 10.8 Hz, 1H), 4.48 (d, *J* = 10.8 Hz, 1H), 4.21–3.70 (m, 12H), 1.11–1.06 (m, 21H). ¹³C NMR (CDCl₃, 75 MHz): δ 165.7, 165.6, 138.7, 138.3, 137.9, 137.8, 133.3, 133.2, 133.0, 129.9, 129.8, 128.5, 128.2, 128.1, 128.0, 127.8, 127.6, 127.5, 127.4, 118.0, 97.9, 96.8, 78.5, 78.1, 75.1, 74.2, 73.9, 72.9, 71.5, 71.3, 70.8, 68.9, 68.8, 68.1, 65.9, 62.4, 18.0, 17.9, 11.9. IR (CHCl₃): ν_{\max} 3067, 2945, 2862, 1718, 1453, 1269, 1113, 1026 cm⁻¹. MALDI-HRMS calcd for C₆₆H₇₈O₁₃SiNa (*m/z*): [MNa⁺] 1129.5109, found 1129.5090.

Allyl 6-O-(2-O-Benzoyl-3,4-di-O-benzyl- α -D-mannopyranosyl)-2-O-benzoyl-3,4-di-O-benzyl- α -D-mannopyranoside (24). AcCl (200 μ L) was slowly added dropwise to a solution of **23** (0.620 g, 0.56 mmol) in CH₂Cl₂ (4.05 mL) and MeOH (20 mL). The solution was stirred at room temperature for 2.5 h before being quenched by dropwise addition of Et₃N (350 μ L). The solvent was removed under reduced pressure and the residue purified by gradient flash silica gel column chromatography (hexanes/EtOAc, 5:1 to 2:1) to give **24** (0.515 g, 96%) as a colorless oil. Spectral data matched that previously reported.⁴⁵

Allyl 6-O-(6-O-(3,4-Di-O-benzyl-2-O-levulinoyl-6-O-triisopropylsilyl- α -D-mannopyranosyl)-2-O-benzoyl-3,4-di-O-benzyl- α -D-mannopyranosyl)-2-O-benzoyl-3,4-di-O-benzyl- α -D-mannopyranoside (25). Imidate **8** (0.550 g, 0.73 mmol) and disaccharide **24** (0.600 g, 0.63 mmol) were combined and coevaporated three times with toluene before being placed under nitrogen and dissolved in CH₂Cl₂ (10 mL). The solution was cooled to 0 °C, TMSOTf (11.4 μ L, 63 μ mol) added dropwise, and the solution stirred for 30 min before being quenched by NEt₃ (20 μ L). The solvent was removed under reduced pressure and the resulting oil purified by gradient flash silica gel column chromatography (hexanes/EtOAc, 5:1 to 3:1) to give **25** (0.780 g, 80%) as a colorless oil. R_f = 0.30 (hexanes/EtOAc, 3:1). $[\alpha]_D^{25}$ = +34.6 (*c* 0.61, CHCl₃). ¹H NMR (CDCl₃, 300 MHz): δ 8.18–8.14 (m, 4H), 7.54–7.47 (m, 6H), 7.37–7.14 (m, 30H), 5.98–5.85 (m, 1H), 5.82 (dd, *J* = 1.9, 2.8 Hz, 1H), 5.72 (dd, *J* = 1.5, 3.1 Hz, 1H), 5.52 (ddt, *J* = 17.1, 10.3, 5.2 Hz, 1H), 5.32 (dq, *J* = 17.1, 1.2 Hz, 1H), 5.22 (dq, *J* = 10.3, 1.5 Hz, 1H), 5.12 (d, *J* = 1.5 Hz, 1H), 5.01 (d, *J* = 1.5 Hz, 1H), 4.94–4.80 (m, 5H), 4.68–4.40 (m, 7H), 4.23–3.56 (m, 18H), 2.76–2.65 (m, 4H), 2.18 (s, 3H), 1.10–1.06 (m, 21H). ¹³C NMR (CDCl₃, 75 MHz): δ 205.9, 171.6, 165.5, 165.3, 138.6, 138.3, 138.1, 137.7, 137.6, 137.4, 133.1, 133.0, 129.8, 129.7, 128.4, 128.1, 128.0, 127.9, 127.6, 127.4, 127.2, 127.1, 117.9, 97.9, 97.8, 96.8, 78.5, 78.1, 77.8, 75.1, 75.0, 74.9, 74.1, 73.8, 73.7, 72.8, 71.5, 71.3, 71.2, 70.9, 70.8, 68.9, 68.5, 68.4, 68.1, 66.0, 65.7, 62.3, 38.0, 29.8, 28.1, 18.0, 12.0. IR (CHCl₃): ν_{\max} 3008, 2942, 2867, 1719, 1270, 1116, 1097 cm⁻¹. MALDI-HRMS calcd for C₉₁H₁₀₆O₂₀SiNa (*m/z*): [MNa⁺] 1569.6944, found 1569.6913.

Allyl 6-O-(6-O-(3,4-Di-O-benzyl-6-O-triisopropylsilyl- α -D-mannopyranosyl)-2-O-benzoyl-3,4-di-O-benzyl- α -D-mannopyranosyl)-2-O-benzoyl-3,4-di-O-benzyl- α -D-mannopyranoside (26). To a solution of **25** (0.765 g, 0.49 mmol) in CH₂Cl₂ (4.8 mL) was added a premixed solution of pyridine (577 μ L) and AcOH (343 μ L). Hydrazine monohydrate (48 μ L, 0.36 mmol) was then added dropwise and the solution stirred for 90 min before being quenched by the addition of acetone (200 μ L). After an additional 10 min, the solvent was removed under reduced pressure and the residue purified by gradient flash silica gel column chromatography (hexanes/EtOAc, 5:1 to 3:1) to give **26** (0.657 g, 92%) as a colorless oil. R_f = 0.26 (hexanes/EtOAc, 3:1). $[\alpha]_D^{25}$ = +33.3 (*c* 1.20, CHCl₃). ¹H NMR (CDCl₃, 300 MHz): δ 8.16–8.10 (m, 4H), 7.53–7.42 (m, 6H), 7.36–7.14 (m, 30H), 5.89 (ddt, *J* = 15.6, 10.5, 4.1 Hz, 1H), 5.78 (dd, *J* = 1.9, 3.0 Hz, 1H), 5.70 (dd, *J* = 1.9, 3.3 Hz, 1H), 5.30 (dq, *J* = 15.6, 1.5 Hz, 1H), 5.20 (dq, *J* = 10.5, 1.5 Hz, 1H), 5.09 (d, *J* = 1.6 Hz, 1H), 5.06 (d, *J* = 1.5 Hz, 1H), 4.99 (d, *J* = 1.9 Hz, 1H), 4.91 (d, *J* = 11.1 Hz, 1H), 4.89 (d, *J* = 11.7 Hz, 1H), 4.87 (d, *J* = 11.4 Hz, 2H), 4.85 (d, *J* = 11.4 Hz, 1H), 4.66 (d, *J* = 10.6 Hz, 1H), 4.65 (d, *J* = 11.4 Hz, 1H), 4.60 (d, *J* = 11.4

(45) Heng, L.; Ning, J.; Kong, F. *Carbohydr. Res.* **2001**, *331*, 431–437.

Hz, 1H), 4.58 (d, $J = 11.4$ Hz, 1H), 4.50 (d, $J = 11.4$ Hz, 1H), 4.48 (d, $J = 11.4$ Hz, 1H), 4.47 (d, $J = 10.8$ Hz, 1H), 4.22–3.59 (m, 18H), 2.29 (d, $J = 3.6$ Hz, 1H), 1.07–1.04 (m, 21H). ^{13}C NMR (CDCl_3 , 75 MHz): δ 165.5, 165.2, 138.4, 138.2, 138.1, 137.6, 137.4, 133.1, 133.0, 129.8, 129.7, 129.6, 128.4, 128.3, 128.1, 128.0, 127.6, 127.4, 127.3, 127.2, 117.9, 99.3, 97.8, 96.8, 79.8, 78.5, 77.9, 75.1, 74.9, 74.0, 73.9, 72.9, 72.5, 71.7, 71.5, 71.4, 71.2, 70.7, 68.9, 68.5, 68.3, 68.1, 66.0, 65.2, 62.5, 18.0, 12.0. IR (CHCl_3): ν_{max} 3569, 3008, 2941, 2867, 1719, 1269, 1118, 1075, 1028 cm^{-1} . MALDI-HRMS calcd for $\text{C}_{86}\text{H}_{100}\text{O}_{18}\text{SiNa}$ (m/z): $[\text{MNa}^+]$ 1471.6577, found 1471.6592.

Allyl 6-O-(6-O-(2-O-(2-O-Benzoyl-3,4,6-tri-O-benzyl- α -D-mannopyranosyl)-3,4-di-O-benzyl- α -D-mannopyranosyl)-2-O-benzoyl-3,4-di-O-benzyl- α -D-mannopyranosyl)-2-O-benzoyl-3,4-di-O-benzyl- α -D-mannopyranoside (28). Imidate **7** (0.627 g, 0.90 mmol) and trisaccharide **26** (1.00 g, 0.69 mmol) were combined and coevaporated three times with toluene before being placed under nitrogen and dissolved in CH_2Cl_2 (10 mL). The solution was then cooled to 0 °C, TMSOTf (19 μL , 0.10 mmol) added dropwise, and the solution stirred for 30 min before being quenched by the addition of NEt_3 (50 μL). The solvent was removed under reduced pressure and the resulting oil purified by gradient flash silica gel column chromatography (hexanes/EtOAc, 5:1 to 3:1) to give **27** (1.23 g, 90%) as a colorless oil. To a solution of **27** (1.23 g, 0.62 mmol) in CH_2Cl_2 (10.5 mL) was then added MeOH (12.6 mL) before AcCl (200 μL) was added dropwise. The solution was stirred at room temperature for 3 h before being quenched by the addition of Et_3N (400 μL). The solvent was removed under reduced pressure and the residue purified by gradient flash silica gel column chromatography (hexanes/EtOAc, 5:1 to 3:1) to give **28** (1.02 g, 90%) as a white foam. $R_f = 0.28$ (hexanes/EtOAc, 3:1). $[\alpha]_{\text{D}} = +18.3$ (c 0.99, CHCl_3). ^1H NMR (CDCl_3 , 300 MHz): δ 8.15–8.06 (m, 6H), 7.57–7.05 (m, 54H), 5.94–5.81 (m, 1H), 5.76–5.74 (m, 2H), 5.68 (dd, $J = 2.1, 3.3$ Hz, 1H), 5.28 (dq, $J = 17.1, 1.5$ Hz, 1H), 5.19 (dq, $J = 10.2, 1.5$ Hz, 1H), 5.10 (d, $J = 1.5$ Hz, 1H), 5.08 (d, $J = 1.5$ Hz, 1H), 4.97–4.96 (m, 2H), 4.90 (d, $J = 10.5$ Hz, 2H), 4.88 (d, $J = 11.7$ Hz, 1H), 4.87 (d, $J = 10.5$ Hz, 1H), 4.84 (d, $J = 12.0$ Hz, 1H), 4.83 (d, $J = 12.0$ Hz, 1H), 4.77 (d, $J = 11.4$ Hz, 1H), 4.63 (d, $J = 12.0$ Hz, 2H), 4.60–4.43 (m, 7H), 4.59 (s, 2H), 4.42 (d, $J = 11.4$ Hz, 2H), 4.18–3.47 (m, 22H). ^{13}C NMR (CDCl_3 , 75 MHz): δ 165.7, 165.5, 165.3, 138.4, 138.3, 137.9, 137.5, 133.2, 133.1, 133.0, 129.8, 129.7, 128.4, 128.3, 128.2, 128.1, 128.0, 127.6, 127.5, 127.4, 127.3, 118.1, 99.5, 99.0, 98.0, 96.9, 79.2, 78.6, 78.0, 77.6, 75.3, 75.0, 74.8, 74.0, 73.7, 73.2, 72.2, 72.1, 71.8, 71.5, 71.4, 71.2, 71.0, 70.7, 68.9, 68.8, 68.7, 68.5, 68.1, 66.0, 65.6, 61.8. IR (CHCl_3): ν_{max} 3066, 3008, 2929, 2873, 1720, 1453, 1362, 1269, 1117 cm^{-1} . MALDI-HRMS calcd for $\text{C}_{111}\text{H}_{112}\text{O}_{24}\text{Na}$ (m/z): $[\text{MNa}^+]$ 1851.7441, found 1851.7403.

Allyl 6-O-(6-O-(2-O-(2-O-Benzoyl-3,4,6-tri-O-benzyl- α -D-mannopyranosyl)-6-O-(3,4-di-O-benzyl-2-O-levulinoyl-6-O-triisopropylsilyl- α -D-mannopyranosyl)-3,4-di-O-benzyl- α -D-mannopyranosyl)-2-O-benzoyl-3,4-di-O-benzyl- α -D-mannopyranosyl)-2-O-benzoyl-3,4-di-O-benzyl- α -D-mannopyranoside (29). Imidate **8** (0.920 g, 1.21 mmol) and tetrasaccharide **28** (1.85 g, 1.01 mmol) were combined and coevaporated three times with toluene before being placed under nitrogen and dissolved in CH_2Cl_2 (18 mL). The solution was then cooled to 0 °C, TMSOTf (18.3 μL , 0.10 mmol) was added dropwise, and the solution was stirred for 30 min before being quenched by the addition of NEt_3 (50 μL). The solvent was removed under reduced pressure and the resulting oil purified by gradient flash silica gel column chromatography (hexanes/EtOAc, 5:1 to 3:1) to give **29** (2.06 g, 85%) as a colorless oil. $R_f = 0.25$ (hexanes/EtOAc, 3:1). $[\alpha]_{\text{D}} = +26.1$ (c 0.64, CHCl_3). ^1H NMR (CDCl_3 , 300 MHz): δ 8.19–8.06 (m, 6H), 7.56–7.51 (m, 4H), 7.38–7.09 (m, 60H), 5.97–5.84 (m, 1H), 5.84–5.83 (m, 1H), 5.78 (t, $J = 2.1$ Hz, 1H), 5.72 (dd, $J = 1.8, 3.0$ Hz, 1H), 5.42–5.40 (m, 1H), 5.31 (dq, $J = 17.4, 1.5$ Hz, 1H), 5.22 (dq, $J = 10.5, 1.5$ Hz, 1H), 5.15 (d, $J = 1.5$ Hz, 1H), 5.14 (d, $J = 1.8$ Hz, 1H), 5.06–5.05 (m, 1H), 4.98 (d, $J = 1.5$ Hz, 1H), 4.95–4.80 (m, 9H), 4.68–

4.39 (m, 14H), 4.22–3.50 (m, 28H), 2.66–2.61 (m, 4H), 2.11 (s, 3H), 1.12–1.08 (m, 21H). ^{13}C NMR (CDCl_3 , 75 MHz): δ 206.2, 171.7, 165.7, 165.5, 165.3, 138.8, 138.6, 138.4, 138.2, 138.0, 137.9, 137.8, 137.6, 133.2, 132.9, 129.9, 129.8, 129.7, 128.5, 128.4, 128.3, 128.1, 128.0, 127.8, 127.6, 127.5, 127.3, 127.2, 127.1, 117.9, 99.7, 99.2, 97.9, 97.7, 97.0, 79.5, 78.5, 78.3, 78.0, 77.8, 75.1, 75.0, 74.9, 74.8, 74.4, 74.1, 73.7, 73.1, 72.5, 72.2, 71.8, 71.6, 71.3, 70.9, 69.0, 68.9, 68.6, 68.1, 66.1, 65.8, 65.6, 62.2, 38.0, 29.7, 28.0, 17.9, 12.0. IR (CHCl_3): ν_{max} 3008, 2940, 2866, 1720, 1453, 1362, 1269, 1115, 1028 cm^{-1} . MALDI-HRMS calcd for $\text{C}_{145}\text{H}_{160}\text{O}_{31}\text{SiNa}$ (m/z): $[\text{MNa}^+]$ 2448.0611, found 2448.0560.

Allyl 6-O-(6-O-(2-O-(2-O-Benzoyl-3,4,6-tri-O-benzyl- α -D-mannopyranosyl)-6-O-(6-O-(2-O-benzoyl-3,4,6-tri-O-benzyl- α -D-mannopyranosyl)-3,4-di-O-benzyl-2-O-levulinoyl- α -D-mannopyranosyl)-3,4-di-O-benzyl- α -D-mannopyranosyl)-2-O-benzoyl-3,4-di-O-benzyl- α -D-mannopyranosyl)-2-O-benzoyl-3,4-di-O-benzyl- α -D-mannopyranoside (30). To a solution of **29** (2.00 g, 0.82 mmol) in CH_2Cl_2 (13 mL) and MeOH (15 mL) was added AcCl (255 μL) dropwise. The solution was then stirred at room temperature for 6 h before being quenched by the addition of Et_3N (500 μL). The solvent was removed under reduced pressure and the residue purified by gradient flash silica gel column chromatography (hexanes/EtOAc, 5:1 to 2:1) to give the corresponding alcohol (1.56 g, 84%) as a colorless oil, $R_f = 0.29$ (hexanes/EtOAc, 2:1). Imidate **7** (0.532 g, 0.76 mmol) and the alcohol (1.50 g, 0.66 mmol) were combined and coevaporated three times with toluene before being placed under nitrogen and dissolved in CH_2Cl_2 (10 mL). The solution was cooled to 0 °C, TMSOTf (12 μL , 66 μmol) was added dropwise, and the solution was stirred for 30 min before being quenched by the addition of NEt_3 (30 μL). The solvent was removed under reduced pressure and the resulting oil purified by gradient flash silica gel column chromatography (hexanes/EtOAc, 5:1 to 2:1) to give **30** (0.170 g, 92%) as a colorless oil. $R_f = 0.22$ (hexanes/EtOAc, 3:1). $[\alpha]_{\text{D}} = +55.7$ (c 0.95, CHCl_3). ^1H NMR (CDCl_3 , 300 MHz): δ 8.16–8.03 (m, 8H), 7.56–7.48 (m, 6H), 7.37–7.07 (m, 76H), 5.88–5.86 (m, 1H), 5.82–5.80 (m, 1H), 5.76 (dd, $J = 2.1, 3.3$ Hz, 1H), 5.75 (dd, $J = 2.1, 3.0$ Hz, 1H), 5.69 (dd, $J = 1.8, 3.0$ Hz, 1H), 5.40 (t, $J = 1.5$ Hz, 1H), 5.28 (dq, $J = 17.1, 1.5$ Hz, 1H), 5.21–5.20 (m, 1H), 5.18 (d, $J = 1.5$ Hz, 1H), 5.13 (d, $J = 1.2$ Hz, 1H), 5.11 (d, $J = 1.8$ Hz, 1H), 5.03 (d, $J = 1.0$ Hz, 1H), 4.95 (d, $J = 1.5$ Hz, 1H), 4.93–4.53 (m, 23H), 4.50 (d, $J = 11.1$ Hz, 1H), 4.47 (d, $J = 10.2$ Hz, 1H), 4.45 (d, $J = 10.2$ Hz, 1H), 4.45 (d, $J = 12.0$ Hz, 1H), 4.43 (d, $J = 12.0$ Hz, 1H), 4.35 (d, $J = 10.2$ Hz, 1H), 4.16–3.46 (m, 33H), 2.74–2.70 (m, 2H), 2.62–2.58 (m, 2H), 2.02 (s, 3H). ^{13}C NMR (CDCl_3 , 75 MHz): δ 205.8, 171.9, 165.6, 165.4, 165.2, 138.5, 138.4, 138.3, 138.2, 138.0, 137.9, 137.7, 137.6, 133.2, 133.0, 129.9, 129.8, 129.7, 128.5, 128.4, 128.3, 128.2, 128.0, 127.8, 127.6, 127.5, 127.4, 127.3, 127.2, 118.0, 99.8, 99.2, 98.1, 97.7, 97.1, 79.6, 78.6, 78.3, 78.1, 77.9, 77.7, 75.2, 75.0, 74.9, 74.5, 74.1, 73.8, 73.6, 73.4, 73.2, 72.3, 71.9, 71.8, 71.7, 71.4, 71.3, 71.2, 71.1, 70.8, 69.1, 69.0, 68.8, 68.6, 68.5, 68.2, 66.6, 65.9, 65.7, 65.1, 37.8, 29.7, 28.3. IR (CHCl_3): ν_{max} 3008, 2928, 2859, 1723, 1453, 1266, 1116, 1093, 975, 909 cm^{-1} . MALDI-HRMS calcd for $\text{C}_{170}\text{H}_{172}\text{O}_{37}\text{Na}$ (m/z): $[\text{MNa}^+]$ 2828.1475, found 2828.1419.

1-O-(6-O-(6-O-(2-O-(2-O-Benzoyl-3,4,6-tri-O-benzyl- α -D-mannopyranosyl)-6-O-(6-O-(2-O-benzoyl-3,4,6-tri-O-benzyl- α -D-mannopyranosyl)-3,4-di-O-benzyl-2-O-levulinoyl- α -D-mannopyranosyl)-3,4-di-O-benzyl- α -D-mannopyranosyl)-2-O-benzoyl-3,4-di-O-benzyl- α -D-mannopyranosyl)-2-O-benzoyl-3,4-di-O-benzyl- α -D-mannopyranosyl) Trichloroacetimidate (2). Hexasaccharide **30** (0.630 g, 0.22 mmol) was dissolved in THF (15 mL) and degassed with argon for 30 min. $\{[\text{Ir}(\text{COD})[\text{PCH}_3(\text{C}_6\text{H}_5)_2]_2]\text{PF}_6$ (0.010 g, 11 μmol) was added and the solution degassed for another 5 min before being purged with hydrogen for 5 min and argon for further 5 min. The solution was stirred at room temperature for 2.5 h before the solvent was removed under reduced pressure. The residue was dissolved in THF/ H_2O (4:1, 25 mL), and iodine (0.168 g, 0.66 mmol) was added. The resulting brown solution was stirred

at room temperature for 1.5 h, quenched by the addition of saturated aqueous Na₂SO₄ solution, and diluted with EtOAc (60 mL). The organic phase was separated and washed twice with water and dried over MgSO₄, and the solvent was removed under reduced pressure. The pale yellow residue was purified by gradient flash silica gel column chromatography (hexanes/EtOAc, 3:1 to 1:1) to give the corresponding lactol (0.566 g, 93%) as a colorless oil. The lactol was dissolved in CH₂Cl₂ (5 mL), trichloroacetonitrile (205 μL, 2.1 mmol) added, and the solution cooled to 0 °C before DBU (3.1 μL, 2.0 μmol) was added. The reaction was stirred at 0 °C for 30 min before being passed through a small silica gel plug, and the plug was washed with EtOAc (80 mL). The solvent was removed under reduced pressure to afford a pale yellow residue that was purified by gradient flash silica gel column chromatography (hexanes/EtOAc, 3:1 to 2:1) to give **2** (0.500 g, 86%) as a colorless oil. *R*_f = 0.53 (hexanes/EtOAc, 2:1). [α]_D = +18.8 (*c* 1.50, CHCl₃). ¹H NMR (CDCl₃, 300 MHz): δ 8.70 (s, 1H), 8.13–8.08 (m, 8H), 7.61–7.54 (m, 6H), 7.40–7.16 (m, 76H), 6.41 (d, *J* = 1.8 Hz, 1H), 5.85–5.84 (m, 2H), 5.81–5.80 (m, 1H), 5.76 (t, *J* = 1.2 Hz, 1H), 5.70 (t, *J* = 1.8 Hz, 1H), 5.38 (t, *J* = 1.8 Hz, 1H), 5.15 (d, *J* = 1.8 Hz, 1H), 5.11 (d, *J* = 1.8 Hz, 1H), 5.06 (d, *J* = 1.5 Hz, 1H), 5.01 (d, *J* = 1.2 Hz, 1H), 4.90–4.31 (m, 29H), 4.14–3.42 (m, 30H), 2.78–2.68 (m, 2H), 2.62–2.05 (m, 2H), 2.01 (s, 3H). ¹³C NMR (CDCl₃, 75 MHz): δ 205.7, 171.7, 165.3, 165.2, 165.1, 159.3, 138.4, 138.3, 138.3, 138.2, 138.1, 137.8, 137.7, 137.6, 137.4, 137.2, 133.3, 133.0, 132.8, 129.8, 129.6, 129.3, 128.5, 128.2, 128.1, 128.1, 128.0, 128.0, 127.9, 127.8, 127.6, 127.4, 127.2, 127.2, 127.1, 127.1, 99.6, 99.1, 97.9, 97.8, 97.6, 95.1, 90.6, 79.5, 78.1, 78.0, 77.7, 77.5, 77.4, 77.0, 76.5, 75.3, 75.1, 74.9, 74.8, 74.3, 74.0, 73.7, 73.6, 73.5, 73.4, 73.3, 73.1, 72.1, 71.8, 71.7, 71.6, 71.6, 71.3, 71.1, 71.1, 71.0, 70.7, 69.0, 68.8, 68.7, 68.6, 68.4, 68.3, 67.5, 66.4, 65.7, 65.4, 65.0, 38.0, 29.6, 28.1. IR (CHCl₃): ν_{max} 3011, 2929, 2862, 1721, 1453, 1362, 1269, 1117, 1092, 1028, 980 cm⁻¹. MALDI-HRMS calcd for C₁₆₉H₁₆₈Cl₃NO₃₇Na (*m/z*): [MNa⁺] 2931.0258, found 2931.0316.

6-(Benzylthio)hexyl 6-O-(6-O-(2-O-(2-O-Benzoyl-3,4,6-tri-O-benzyl-α-D-mannopyranosyl)-6-O-(6-O-(2-O-benzoyl-3,4,6-tri-O-benzyl-α-D-mannopyranosyl)-3,4-di-O-benzyl-α-D-mannopyranosyl)-3,4-di-O-benzyl-α-D-mannopyranosyl)-2-O-benzoyl-3,4-di-O-benzyl-α-D-mannopyranosyl)-2-O-benzoyl-3,4-di-O-benzyl-α-D-mannopyranoside (3). Imidate **2** (0.286 g, 0.098 mmol) and 6-(benzylthio)hexan-1-ol (0.033 g, 0.15 mmol) were combined and coevaporated three times with toluene before being placed under nitrogen and dissolved in CH₂Cl₂ (2 mL). The solution was then cooled to 0 °C, TMSOTf (50 μL of a 0.036 M solution in CH₂Cl₂, 9.8 μmol) was added dropwise, and the solution was stirred for 30 min before being quenched by the addition of NEt₃ (10 μL). The solvent was removed under reduced pressure, and the resulting oil was passed through a small silica gel plug, washing with hexanes/EtOAc (3:1, 50 mL). The solution was dissolved in pyridine (3.66 mL), acetic anhydride (2.18 mL) added, and the solution stirred at room temperature for 16 h. The reaction was quenched by the slow addition of water and extracted with EtOAc, and the organic extracts were dried over MgSO₄. The solvent was removed under reduced pressure by coevaporation with toluene and the residue purified by gradient flash silica gel column chromatography (hexanes/EtOAc, 20:1 to 5:1) to give **31** (0.260 g, 89%), *R*_f = 0.33 (hexanes/EtOAc, 2:1), and the acetylated linker 6-(benzylthio)hexyl acetate, *R*_f = 0.25 (hexanes/EtOAc, 2:1), that was discarded. A premixed solution of pyridine (1.32 mL) and AcOH (785 μL) was then added to **31** (0.250 g, 84 μmol) and hydrazine monohydrate (50 μL of a 0.16 M solution in CH₂Cl₂, 0.17 mmol) was added dropwise. The reaction was stirred at room temperature for 90 min before being quenched by the addition of acetone (50 μL). The solution was stirred for another 15 min at room temperature before the solvent was removed under reduced pressure and the residue purified by gradient flash silica gel column chromatography (hexanes/EtOAc, 5:1 to 2:1) to give **3** (0.231 g, 96%) as a white foam. *R*_f = 0.56 (hexanes/EtOAc, 2:1). [α]_D = +28.9 (*c* 1.00, CHCl₃). ¹H NMR

(CDCl₃, 300 MHz): δ 8.15–8.03 (m, 8H), 7.56–7.46 (m, 6H), 7.37–7.10 (m, 81H), 5.79–5.75 (m, 2H), 5.74 (dd, *J* = 1.8, 3.0 Hz, 1H), 5.64 (dd, *J* = 1.5, 3.0 Hz, 1H), 5.11 (d, *J* = 1.8 Hz, 1H), 5.10–5.09 (m, 2H), 5.06 (d, *J* = 1.8 Hz, 1H), 5.04 (d, *J* = 1.2 Hz, 1H), 4.92–4.35 (m, 30H), 4.16–3.33 (m, 33H), 3.69 (s, 2H), 2.73 (d, *J* = 3.3 Hz, 1H), 2.40 (t, *J* = 6.9 Hz, 2H), 1.57–1.51 (m, 4H), 1.35–1.27 (m, 4H). ¹³C NMR (CDCl₃, 75 MHz): δ 165.8, 165.5, 165.4, 165.4, 138.6, 138.5, 138.3, 138.0, 137.9, 137.8, 137.7, 137.6, 133.2, 133.0, 132.9, 130.0, 129.9, 129.8, 129.7, 128.8, 128.5, 128.4, 128.3, 128.2, 128.1, 127.9, 127.8, 127.7, 127.6, 127.5, 127.4, 127.3, 127.2, 126.8, 99.9, 98.9, 98.3, 98.0, 97.8, 79.6, 79.2, 78.6, 78.1, 77.2, 76.0, 75.4, 75.1, 75.0, 74.7, 74.1, 73.8, 73.6, 73.3, 73.2, 72.0, 71.7, 71.1, 70.8, 69.0, 68.7, 67.8, 67.6, 66.2, 65.9, 65.7, 65.0, 36.2, 31.3, 29.2, 29.0, 28.6, 25.8. IR (CHCl₃): ν_{max} 3036, 3007, 2928, 1721, 1496, 1453, 1362, 1269, 1117, 1077, 1028, 980, 909 cm⁻¹. MALDI-HRMS calcd for C₁₇₅H₁₈₀O₃₅SNa (*m/z*): [MNa⁺] 2896.1924, found 2896.1823.

6-Thiohexyl 6-O-(6-O-(2-O-(α-D-Mannopyranosyl)-6-O-(6-O-(α-D-mannopyranosyl)-α-D-mannopyranosyl)-α-D-mannopyranosyl)-α-D-mannopyranoside (13). Liquid ammonia (15 mL) was condensed in a three-necked receiver flask cooled to -78 °C in a cooling bath. Small pieces of sodium were then added until a bright blue solution was obtained. To this solution was added dropwise a solution of hexasaccharide **3** (0.065 g, 0.023 mmol) in THF (10 mL). The bright blue solution was stirred at -78 °C for 2 h before being quenched by the dropwise addition of MeOH. The cooling bath was then removed, and the ammonia was removed by bubbling nitrogen through the solution. After neutralization with Amberlite IR 120 resin, the solution was filtered through a glass frit, washing with 100 mL of MeOH, and the solvent removed under reduced pressure to give crude **13** as a very pale yellow oil. The residue was purified by gradient reversed-phase C₁₈ column chromatography (H₂O/MeOH, 1:0 to 0:1) and freeze-dried to give **13** (0.0233 mg, 92%) isolated as the sulfur-linked dimer as a white amorphous solid. [α]_D = +70.6 (*c* 0.57, H₂O). ¹H NMR (D₂O, 300 MHz): δ 5.12 (d, *J* = 1.4 Hz, 2H), 5.03 (d, *J* = 1.7 Hz, 2H), 4.89 (m, 4H), 4.88 (d, *J* = 1.4 Hz, 2H), 4.84 (d, *J* = 1.6 Hz, 2H), 4.07 (dd, *J* = 1.8, 3.3 Hz, 2H), 4.02–3.63 (m, 70H), 3.62–3.52 (m, 2H), 2.77 (t, *J* = 7.1 Hz, 4H), 1.74–1.61 (m, 8H), 1.46–1.40 (m, 8H). ¹³C NMR (D₂O, 75 MHz): δ 105.0, 102.7, 102.3, 102.1, 100.8, 81.6, 75.9, 75.4, 73.7, 73.6, 73.3, 73.1, 72.8, 72.7, 70.6, 69.4, 69.3, 69.2, 69.1, 68.6, 68.4, 68.3, 67.8, 63.7, 63.6, 40.9, 31.0, 30.9, 29.8, 27.7. ESI-HRMS calcd for C₈₄H₁₄₆O₆₂S₂-Na₂(*m/z*): [M2Na²⁺] 1128.3749, found 1128.3745.

Allyl 6-O-(6-O-(2-O-Acetyl-3,4,6-tri-O-benzyl-α-D-mannopyranosyl)-2-O-benzoyl-3,4-di-O-benzyl-α-D-mannopyranosyl)-2-O-benzoyl-3,4-di-O-benzyl-α-D-mannopyranoside (33). Glycosyl trichloroacetimidate **32** (0.600 g, 0.94 mmol) and disaccharide **24** (0.727 g, 0.66 mmol) were combined and coevaporated three times with toluene before being placed under nitrogen and dissolved in CH₂Cl₂ (20 mL). The solution was cooled to 0 °C, TMSOTf (12 μL, 0.10 mmol) added dropwise, and the solution stirred for 30 min before being quenched by the addition of NEt₃ (20 μL). The solvent was removed under reduced pressure and the resulting oil purified by gradient flash silica gel column chromatography (hexanes/EtOAc, 5:1 to 3:1) to give **33** (0.918 g, 98%) as a colorless oil. Spectral data matched that previously reported.⁴⁵

Allyl 6-O-(6-O-(3,4,6-Tri-O-benzyl-α-D-mannopyranosyl)-2-O-benzoyl-3,4-di-O-benzyl-α-D-mannopyranosyl)-2-O-benzoyl-3,4-di-O-benzyl-α-D-mannopyranoside (34). AcCl (130 μL) was added dropwise to a solution of trisaccharide **32** (0.520 g, 0.36 mmol) in CH₂Cl₂ (2.6 mL) and MeOH (13 mL). The solution was stirred for 48 h at room temperature before additional AcCl (130 μL) was added, and the solution stirred for further 24 h. The solution was quenched by the dropwise addition of NEt₃ (350 μL) and the solvent removed under reduced pressure. The residue was purified by gradient flash silica gel column chromatography (hexanes/EtOAc, 3:1 to 2:1) to give **34** (0.469 g, 93%) as a colorless oil. *R*_f = 0.34 (hexanes/EtOAc, 2:1). [α]_D = +37.7 (*c* 0.35, CHCl₃).

¹H NMR (CDCl₃, 300 MHz): δ 8.14–8.08 (m, 4H), 7.51–7.12 (m, 41H), 5.95–5.82 (m, 1H), 5.76 (dd, *J* = 2.2, 3.0 Hz, 1H), 5.68 (dd, *J* = 1.9, 3.1 Hz, 1H), 5.29 (dq, *J* = 17.1, 1.5 Hz, 1H), 5.19 (dq, *J* = 10.2, 1.5 Hz, 1H), 5.14 (d, *J* = 1.6 Hz, 1H), 5.07 (d, *J* = 1.6 Hz, 1H), 4.98 (d, *J* = 1.6 Hz, 1H), 4.90 (d, *J* = 11.1 Hz, 1H), 4.88 (d, *J* = 12.3 Hz, 1H), 4.48 (d, *J* = 11.1 Hz, 1H), 4.80 (d, *J* = 10.5 Hz, 1H), 4.79 (d, *J* = 11.1 Hz, 1H), 4.64–4.42 (m, 9H), 4.20–3.54 (m, 18H), 2.37 (d, *J* = 3.0 Hz, 1H). ¹³C NMR (CDCl₃, 75 MHz): δ 165.7, 165.4, 138.4, 138.3, 138.2, 138.1, 137.8, 137.6, 133.2, 133.1, 129.8, 128.5, 128.4, 128.3, 128.2, 128.1, 127.8, 127.7, 127.6, 127.5, 127.4, 118.1, 99.4, 97.9, 96.9, 79.9, 78.6, 78.1, 75.2, 75.1, 75.1, 74.2, 74.2, 74.0, 73.4, 71.8, 71.7, 71.5, 71.4, 71.2, 70.9, 69.0, 68.7, 68.6, 68.3, 68.3, 66.2, 65.5. IR (CHCl₃): ν_{max} 3559, 3067, 3035, 3005, 2933, 2872, 1712, 1451, 1359, 1267, 1118 cm⁻¹. MALDI-HRMS calcd for C₈₄H₈₆O₁₈Na (*m/z*): [MNa⁺] 1405.5712, found 1405.5681.

Allyl 6-*O*-(6-*O*-(2-*O*-(2-*O*-Acetyl-3,4,6-tri-*O*-benzyl-α-*D*-mannopyranosyl)-3,4,6-tri-*O*-benzyl-α-*D*-mannopyranosyl)-2-*O*-benzoyl-3,4-di-*O*-benzyl-α-*D*-mannopyranosyl)-2-*O*-benzoyl-3,4-di-*O*-benzyl-α-*D*-mannopyranoside (35). Imidate **32** (0.543 g, 0.85 mmol) and trisaccharide **34** (0.993 g, 0.71 mmol) were combined and coevaporated three times with toluene before being placed under nitrogen and dissolved in CH₂Cl₂ (12 mL). The solution was cooled to 0 °C, TMSOTf (6 μL, 0.032 mmol) was added dropwise, and the solution stirred for 30 min before being quenched by the addition of NEt₃ (12 μL). The solvent was removed under reduced pressure and the resulting oil purified by gradient flash silica gel column chromatography (toluene/EtOAc, 50:1 to 20:1) to give **35** (1.08 g, 83%) as a colorless oil. *R*_f = 0.50 (toluene/EtOAc, 10:1). [α]_D = +25.8 (*c* 1.88, CHCl₃). ¹H NMR (CDCl₃, 300 MHz): δ 8.16–8.09 (m, 4H), 7.51–7.11 (m, 56H), 5.95–5.82 (m, 1H), 5.76 (dd, *J* = 1.5, 2.8 Hz, 1H), 5.69 (dd, *J* = 1.5, 3.0 Hz, 1H), 5.54 (dd, *J* = 1.5, 2.7 Hz, 1H), 5.34–5.26 (m, 1H), 5.21–5.18 (m, 1H), 5.10 (d, *J* = 1.5 Hz, 1H), 5.07 (d, *J* = 1.5 Hz, 1H), 5.00 (d, *J* = 1.5 Hz, 1H), 4.97 (d, *J* = 1.5 Hz, 1H), 4.91–4.76 (m, 5H), 4.66–4.34 (m, 15H), 4.19–3.47 (m, 23H), 2.12 (s, 3H). ¹³C NMR (CDCl₃, 75 MHz): δ 170.1, 165.8, 165.5, 138.6, 138.5, 138.4, 138.3, 138.2, 138.1, 137.9, 137.6, 133.3, 130.0, 129.8, 128.6, 128.5, 128.3, 128.2, 127.9, 127.7, 127.6, 127.5, 127.4, 127.3, 118.1, 99.6, 99.1, 98.0, 97.0, 79.5, 78.6, 78.1, 75.2, 75.0, 74.9, 74.7, 74.4, 74.2, 73.8, 73.3, 73.2, 72.0, 71.9, 71.7, 71.6, 71.3, 71.0, 70.9, 69.0, 68.9, 68.8, 68.6, 68.2, 66.1, 66.0, 21.2. IR (CHCl₃): ν_{max} 3056, 3005, 2923, 2866, 1723, 1496, 1364, 1262, 1113, 1097, 1028, 980 cm⁻¹. MALDI-HRMS calcd for C₁₁₃H₁₁₆O₂₄Na (*m/z*): [MNa⁺] 1879.7754, found 1879.7714.

6-*O*-(6-*O*-(2-*O*-(2-*O*-Acetyl-3,4,6-tri-*O*-benzyl-α-*D*-mannopyranosyl)-3,4,6-tri-*O*-benzyl-α-*D*-mannopyranosyl)-2-*O*-benzoyl-3,4-di-*O*-benzyl-α-*D*-mannopyranosyl)-2-*O*-benzoyl-3,4-di-*O*-benzyl-α-*D*-mannopyranosyl Trichloroacetimidate (36). To tetrasaccharide **35** (0.146 g, 0.09 mmol), coevaporated three times with toluene under argon, was added THF (10 mL) and the solution degassed for 30 min with argon. {Ir(COD)[PCH₃(C₆H₅)₂]₂}PF₆ (4.0 mg, 4.0 μmol) was added and the solution degassed for a further 5 min before being flushed with hydrogen for 5 min. The solution was then purged with argon for 10 min and stirred at room temperature for 2 h before the solvent was removed under reduced pressure. The resulting oil was passed through a small silica gel plug (hexanes/EtOAc, 1:1). The solvent was removed under reduced pressure, the residue dissolved in THF/H₂O (4:1, 11.3 mL), and iodine (0.069 g, 0.27 mmol) added. The solution was stirred at room temperature for 90 min before being quenched by the addition of saturated aqueous Na₂S₂O₃ solution (20 mL) and extracted with EtOAc. The organic extract was washed twice with water and once with brine and dried over MgSO₄ and the solvent removed under reduced pressure. The resulting oil was purified by gradient flash silica gel column chromatography (hexanes/EtOAc, 5:1 to 3:1) to give the corresponding lactol (0.136 g, 82%). The lactol was then dissolved in CH₂Cl₂ (1 mL) and the solution cooled to 0 °C before trichloroacetonitrile (74 μL, 0.74 mmol) and then DBU (100 μL

of a 0.011 M solution in CH₂Cl₂, 7.4 μmol) were added. The solution was stirred at 0 °C for 30 min before being filtered through a small silica gel plug, washing with EtOAc (50 mL), and the solvent removed under reduced pressure. The resulting oil was purified by gradient flash silica gel chromatography (hexanes/EtOAc, 5:1 to 3:1) to give **36** (0.117 g, 81%, 3 steps) as a colorless oil. *R*_f = 0.38 (hexanes/EtOAc, 3:1). [α]_D = +24.3 (*c* 0.91, CHCl₃). ¹H NMR (CDCl₃, 300 MHz): δ 8.73 (s, 1H), 8.19–8.10 (m, 4H), 7.55–7.13 (m, 56H), 6.39 (d, *J* = 1.8 Hz, 1H), 5.82 (dd, *J* = 1.2, 2.7 Hz, 1H), 5.73 (dd, *J* = 1.2, 2.6 Hz, 1H), 5.56 (dd, *J* = 1.5, 2.7 Hz, 1H), 5.11 (d, *J* = 1.5 Hz, 1H), 5.04 (d, *J* = 1.3 Hz, 1H), 5.01 (d, *J* = 1.2 Hz, 1H), 4.91 (d, *J* = 10.8 Hz, 1H), 4.88 (d, *J* = 10.8 Hz, 1H), 4.85 (d, *J* = 10.8 Hz, 1H), 4.84 (d, *J* = 11.4 Hz, 1H), 4.78 (d, *J* = 11.1 Hz, 1H), 4.67–4.36 (m, 15H), 4.20–3.49 (m, 21H), 2.14 (s, 3H). ¹³C NMR (CDCl₃, 75 MHz): δ 170.1, 165.5, 165.4, 160.0, 138.5, 138.4, 138.2, 138.0, 137.9, 137.6, 137.4, 133.5, 133.2, 129.9, 129.8, 129.5, 128.6, 128.4, 128.3, 128.2, 128.1, 127.9, 127.8, 127.7, 127.6, 127.4, 127.3, 99.5, 99.1, 97.8, 96.0, 90.7, 79.4, 78.2, 78.1, 77.8, 75.3, 75.0, 74.9, 74.6, 74.4, 74.1, 73.7, 73.5, 73.3, 73.1, 72.0, 71.9, 71.7, 71.3, 70.9, 68.8, 68.7, 68.5, 67.6, 65.9, 65.7, 21.1. IR (CHCl₃): ν_{max} 3067, 3026, 2923, 2862, 1723, 1267, 1113, 1092, 974 cm⁻¹. MALDI-HRMS calcd for C₁₁₂H₁₁₂Cl₃NO₂₄Na (*m/z*): [MNa⁺] 1982.6538, found 1982.6532.

6-(Benzylthio)hexyl 6-*O*-(6-*O*-(2-*O*-(2-*O*-Acetyl-3,4,6-tri-*O*-benzyl-α-*D*-mannopyranosyl)-3,4,6-tri-*O*-benzyl-α-*D*-mannopyranosyl)-2-*O*-benzoyl-3,4-di-*O*-benzyl-α-*D*-mannopyranosyl)-2-*O*-benzoyl-3,4-di-*O*-benzyl-α-*D*-mannopyranoside (37). Imidate **36** (0.110 g, 0.056 mmol) and 6-(benzylthio)hexan-1-ol (0.019 g, 84 μmol) were combined and coevaporated three times with toluene before being placed under nitrogen and dissolved in CH₂Cl₂ (1 mL). The solution was then cooled to 0 °C, and TMSOTf (50 μL of a 0.022 M solution in CH₂Cl₂, 60 μmol) was added dropwise. The solution was stirred for 30 min before being quenched by the addition of NEt₃ (20 μL). The solvent was removed under reduced pressure, and the resulting oil was dissolved in pyridine (1 mL) before acetic anhydride (500 μL) was added dropwise. The solution was stirred at room temperature for 16 h before being quenched by the slow addition of water, extracted with EtOAc, and the organic extracts dried over MgSO₄. The solvent was removed under reduced pressure by coevaporation with toluene and the residue purified by gradient flash silica gel column chromatography (hexanes/EtOAc, 5:1 to 3:1) to give **37** (0.105 g, 93%) as a colorless oil. *R*_f = 0.38 (hexanes/EtOAc, 3:1). [α]_D = +21.6 (*c* 0.90, CHCl₃). ¹H NMR (CDCl₃, 300 MHz): δ 8.16–8.08 (m, 4H), 7.51–7.12 (m, 61H), 5.77 (dd, *J* = 1.8, 3.1 Hz, 1H), 5.66 (dd, *J* = 1.8, 3.3 Hz, 1H), 5.55 (dd, *J* = 1.9, 3.0 Hz, 1H), 5.10 (d, *J* = 1.8 Hz, 1H), 5.09 (d, *J* = 1.7 Hz, 1H), 5.00 (d, *J* = 1.6 Hz, 1H), 4.91 (d, *J* = 1.6 Hz, 1H), 4.90–4.76 (m, 5H), 4.64 (d, *J* = 10.9 Hz, 1H), 4.61 (d, *J* = 11.9 Hz, 1H), 4.60 (d, *J* = 11.7 Hz, 1H), 4.57 (d, *J* = 10.9 Hz, 2H), 4.55 (d, *J* = 11.7 Hz, 1H), 4.53 (d, *J* = 11.1 Hz, 1H), 4.49–4.35 (m, 8H), 4.15–3.37 (m, 23H), 3.70 (s, 2H), 2.41 (t, *J* = 7.1 Hz, 2H), 2.13 (s, 3H), 1.61–1.51 (m, 4H), 1.44–1.22 (m, 4H). ¹³C NMR (CDCl₃, 75 MHz): δ 170.1, 165.9, 165.5, 138.7, 138.6, 138.5, 138.4, 138.3, 138.1, 138.0, 137.6, 133.3, 130.0, 129.9, 128.9, 128.6, 128.5, 128.4, 128.3, 128.2, 127.9, 127.8, 127.7, 127.5, 127.4, 127.3, 126.9, 99.6, 99.1, 98.1, 97.9, 79.5, 78.7, 78.3, 78.2, 77.3, 75.2, 75.1, 74.9, 74.8, 74.5, 74.3, 73.9, 73.4, 73.2, 72.1, 72.0, 71.9, 71.8, 71.7, 71.4, 71.1, 70.8, 69.1, 68.8, 68.6, 67.9, 66.2, 36.3, 31.4, 29.3, 29.1, 28.7, 25.9, 21.2. IR (CHCl₃): ν_{max} 3067, 3008, 2932, 2862, 1721, 1496, 1453, 1363, 1266, 1098, 1028, 974 cm⁻¹. MALDI-HRMS calcd for C₁₂₃H₁₃₀O₂₄SNa (*m/z*): [MNa⁺] 2045.8570, found 2045.8573.

6-Thiohexyl 6-*O*-(6-*O*-(2-*O*-(α-*D*-Mannopyranosyl)-α-*D*-mannopyranosyl)-α-*D*-mannopyranosyl)-α-*D*-mannopyranoside (14). Liquid ammonia (15 mL) was condensed in a three-necked receiver flask cooled to –78 °C in a cooling bath. Small pieces of sodium were added until a bright blue solution was obtained. A solution of tetrasaccharide **38** (0.040 g, 19.8 μmol) in THF (10 mL) was added dropwise. The bright blue solution was stirred at

–78 °C for 2 h before being quenched by the dropwise addition of MeOH. The cooling bath was removed and the ammonia removed by bubbling nitrogen through the solution. After neutralization with Amberlite IR 120 resin, the solution was filtered through a glass frit, washing with 100 mL of MeOH, and the solvent removed under reduced pressure to give crude **14** as a very pale yellow oil. The residue was then purified by gradient reversed-phase C₁₈ column chromatography (H₂O/MeOH, 1:0 to 0:1) and freeze-dried to give pure **14** (0.018 g, 93%) isolated as the sulfur linked dimer as a white amorphous solid. $[\alpha]_D = +60.2$ (c 0.47, H₂O). ¹H NMR (D₂O, 300 MHz): δ 5.13 (d, *J* = 1.2 Hz, 2H), 5.02 (d, *J* = 1.8 Hz, 2H), 4.87 (d, *J* = 1.2 Hz, 2H), 4.83 (d, *J* = 1.5 Hz, 2H), 4.06 (dd, *J* = 1.8, 3.3 Hz, 2H), 4.00–3.51 (m, 50H), 2.76 (t, *J* = 7.2 Hz, 4H), 1.74–1.58 (m, 8H), 1.44–1.37 (m, 8H). ¹³C NMR (D₂O, 75 MHz): δ 105.0, 102.7, 102.3, 100.8, 81.4, 75.9, 75.4, 73.8, 73.6, 73.0, 72.9, 72.8, 72.7, 70.6, 69.6, 69.3, 69.2, 68.6, 68.4, 63.8, 63.6, 40.9, 31.1, 30.9, 29.9, 27.7. ESI-HRMS calcd for C₆₀H₁₀₆O₄₂S₂Na₂ (*m/z*): [M₂Na⁺] 804.2692, found 804.2693.

Pent-4-enyl 5-O-(2-O-Benzoyl-3-O-benzyl-5-O-triisopropyl- α -D-arabinofuranosyl)-2-O-benzoyl-3-O-benzyl- α -D-arabinofuranoside (44). A solution of **12b** (1.29 g, 2.27 mmol) in anhydrous MeOH/CH₂Cl₂ (4:1, 30 mL) was cooled to 0 °C, and AcCl (1.60 mL, 22.4 mmol) was added. After 3 h at 0 °C, the reaction was quenched by addition of saturated aqueous NaHCO₃ solution (50 mL). The aqueous layer was extracted with CH₂Cl₂ (4 × 100 mL). The combined organic extracts were washed with brine (200 mL), dried over Na₂SO₄, filtered, and evaporated. Purification by flash silica gel column chromatography (hexanes/EtOAc, 5:1) yielded pent-4-enyl 2-O-benzoyl-3-O-benzyl- α -D-arabinofuranoside (0.894 g, 96%) as a colorless oil. *R*_f = 0.20 (hexanes/EtOAc, 3:1). $[\alpha]_D = +80.7$ (c 0.55, CHCl₃). ¹H NMR (CDCl₃, 300 MHz): δ 8.02–7.98 (m, 2H), 7.60–7.54 (m, 1H), 7.46–7.41 (m, 2H), 7.34–7.21 (m, 5H), 5.88–5.74 (m, 1H), 5.36 (d, *J* = 1.5 Hz, 1H), 5.12 (s, 1H), 5.06–4.92 (m, 2H), 4.81 (d, *J* = 12.2 Hz, 1H), 4.59 (d, *J* = 12.2 Hz, 1H), 4.24–4.20 (m, 1H), 4.07–4.04 (m, 1H), 3.90–3.83 (m, 1H), 3.74 (td, *J* = 6.7, 9.5 Hz, 1H), 3.69–3.60 (m, 1H), 3.48 (td, *J* = 6.4, 9.5 Hz, 1H), 2.19–2.11 (m, 2H), 1.80–1.67 (m, 3H). ¹³C NMR (CDCl₃, 75 MHz): δ 165.4, 138.1, 137.6, 133.4, 129.7, 129.4, 128.5, 128.4, 127.8, 114.9, 106.2, 82.9, 82.1, 72.4, 66.9, 62.0, 30.2, 28.6. IR (CHCl₃): ν_{\max} 3590, 3005, 1718, 1451, 1318, 1267, 1108, 1036 cm⁻¹. MALDI-HRMS calcd for C₂₄H₂₈O₆Na (*m/z*): [MNa⁺] 435.1784, found 435.1767.

Imidate 12a (6.57 g, 10.2 mmol) and pent-4-enyl 2-O-benzoyl-3-O-benzyl- α -D-arabinofuranoside (3.50 g, 8.49 mmol) were combined, coevaporated with anhydrous toluene (5 × 25 mL), and dried in vacuo overnight. The mixture was dissolved in anhydrous CH₂Cl₂ (140 mL) and cooled to –40 °C, and TMSOTf (0.20 mL, 1.03 mmol) was added. After 1 h at –40 to –30 °C, the suspension was treated with Et₃N, the solution was stirred for 10 min at room temperature, and the solvents were removed in vacuo. Purification by flash silica gel column chromatography (hexanes/EtOAc, 10:1) gave disaccharide **44** (7.15 g, 94%) as a colorless oil. *R*_f = 0.37 (hexanes/EtOAc, 7:1). $[\alpha]_D = +66.7$ (c 0.39, CHCl₃). ¹H NMR (CDCl₃, 300 MHz): δ 8.02–7.94 (m, 4H), 7.56–7.47 (m, 2H), 7.41–7.34 (m, 4H), 7.30–7.12 (m, 10H), 5.84–5.70 (m, 1H), 5.39 (d, *J* = 1.1 Hz, 1H), 5.35 (d, *J* = 1.5 Hz, 1H), 5.22 (s, 1H), 5.09 (s, 1H), 5.01–4.88 (m, 2H), 4.73 (d, *J* = 11.9 Hz, 1H), 4.62 (d, *J* = 12.1 Hz, 1H), 4.55 (d, *J* = 11.9 Hz, 1H), 4.47 (d, *J* = 12.1 Hz, 1H), 4.32–4.28 (m, 1H), 4.14–4.12 (m, 1H), 4.10–4.03 (m, 2H), 3.89 (dd, *J* = 4.1, 11.4 Hz, 1H), 3.75–3.67 (m, 4H), 3.44 (td, *J* = 6.4, 9.6 Hz, 1H), 2.14–2.07 (m, 2H), 1.72–1.63 (m, 2H), 1.04–0.89 (m, 21H). ¹³C NMR (CDCl₃, 75 MHz): δ 165.5, 165.3, 138.2, 137.9, 137.8, 133.3, 133.2, 129.8, 129.7, 129.6, 129.5, 128.4, 128.3, 128.2, 127.8, 127.7, 127.6, 127.5, 114.8, 106.1, 106.0, 84.0, 83.4, 82.9, 82.1, 82.0, 81.5, 72.3, 72.0, 66.7, 65.5, 62.6, 30.2, 28.6, 17.9, 11.8. IR (CHCl₃): ν_{\max} 2944, 2862, 1718, 1451, 1267, 1113, 1067 cm⁻¹. MALDI-HRMS calcd for C₅₂H₆₆O₁₁SiNa (*m/z*): [MNa⁺] 917.4272, found 917.4282.

Pent-4-enyl 5-O-(2-O-Benzoyl-3-O-benzyl- α -D-arabinofuranosyl)-2-O-benzoyl-3-O-benzyl- α -D-arabinofuranoside (45). A solution of **44** (7.15 g, 7.99 mmol) in anhydrous MeOH/CH₂Cl₂ (4:1, 160 mL) was cooled to 0 °C, and AcCl (5.70 mL, 79.9 mmol) was added. After 4 h at 0 °C, the reaction was quenched by addition of saturated aqueous NaHCO₃ solution (200 mL). The aqueous layer was extracted with CH₂Cl₂ (4 × 300 mL). The combined organic extracts were washed with brine (400 mL), dried over Na₂SO₄, filtered, and evaporated. Purification by gradient flash silica gel column chromatography (hexanes/EtOAc, 4:1 to 3:1) yielded **45** (5.44 g, 92%) as a colorless oil. *R*_f = 0.20 (hexanes/EtOAc, 3:1). $[\alpha]_D = +106.9$ (c 0.29, CHCl₃). ¹H NMR (CDCl₃, 300 MHz): δ 8.05 (d, *J* = 7.6 Hz, 2H), 8.00 (d, *J* = 7.6 Hz, 2H), 7.61–7.53 (m, 2H), 7.47–7.40 (m, 4H), 7.36–7.20 (m, 10H), 5.89–5.76 (m, 1H), 5.41 (s, 2H), 5.28 (s, 1H), 5.16 (s, 1H), 5.06–4.95 (m, 2H), 4.82 (d, *J* = 12.1 Hz, 1H), 4.66 (d, *J* = 11.4 Hz, 1H), 4.63 (d, *J* = 11.5 Hz, 1H), 4.48 (d, *J* = 12.1 Hz, 1H), 4.37–4.33 (m, 1H), 4.17 (d, *J* = 5.6 Hz, 1H), 4.11–4.07 (m, 1H), 3.99–3.90 (m, 2H), 3.83–3.73 (m, 3H), 3.61–3.46 (m, 2H), 2.20–2.12 (m, 2H), 1.80–1.69 (m, 3H). ¹³C NMR (CDCl₃, 75 MHz): δ 165.5, 165.2, 138.2, 137.8, 137.6, 133.4, 133.3, 129.8, 129.7, 129.5, 129.4, 128.5, 128.3, 127.8, 127.7, 127.6, 114.8, 106.2, 106.0, 83.3, 82.8, 82.1, 81.8, 81.4, 72.3, 72.2, 66.8, 65.7, 61.9, 30.2, 28.6. IR (CHCl₃): ν_{\max} 3590, 2933, 1718, 1451, 1267, 1113, 1072, 1026 cm⁻¹. MALDI-HRMS calcd for C₄₃H₄₆O₁₁Na (*m/z*): [MNa⁺] 761.2938, found 761.2945.

Pent-4-enyl 5-O-(5-O-(2-O-Benzoyl-5-O-triisopropylsilyl- α -D-arabinofuranosyl)-2-O-benzoyl-3-O-benzyl- α -D-arabinofuranoside (47). Disaccharide **45** (4.60 g, 6.23 mmol) and imidate **11** (4.86 g, 7.47 mmol) were coevaporated with anhydrous toluene (4 × 25 mL) and dried in vacuo overnight. The mixture was dissolved in anhydrous CH₂Cl₂ (100 mL) and cooled to –40 °C, and TMSOTf (0.14 mL, 0.72 mmol) was added. After 45 min at –40 to –30 °C, the suspension was treated with Et₃N, the solution was stirred for 15 min at room temperature, and the solvents were evaporated. Purification by flash silica gel column chromatography (hexanes/EtOAc, 4:1) gave trisaccharide **46** (3.35 g, 44%) as a colorless oil and a mixture of **46** and trichloroacetamide. **46**: *R*_f = 0.30 (hexanes/EtOAc, 3:1). $[\alpha]_D = +79.6$ (c 0.24, CHCl₃). ¹H NMR (CDCl₃, 300 MHz): δ 8.06–7.98 (m, 6H), 7.59–7.52 (m, 3H), 7.47–7.38 (m, 6H), 7.36–7.18 (m, 10H), 5.88–5.74 (m, 1H), 5.44 (s, 1H), 5.39 (d, *J* = 1.5 Hz, 1H), 5.29 (s, 2H), 5.24 (d, *J* = 5.2 Hz, 1H), 5.21 (s, 1H), 5.14 (s, 1H), 5.05–4.92 (m, 2H), 4.80 (d, *J* = 12.3 Hz, 1H), 4.67 (d, *J* = 12.3 Hz, 1H), 4.62 (d, *J* = 12.3 Hz, 1H), 4.52 (d, *J* = 12.3 Hz, 1H), 4.36–4.31 (m, 1H), 4.21–4.15 (m, 2H), 4.04 (d, *J* = 5.2 Hz, 1H), 3.99–3.72 (m, 7H), 3.65 (dd, *J* = 3.7, 11.1 Hz, 1H), 3.48 (td, *J* = 6.4, 9.6 Hz, 1H), 2.66–2.34 (m, 3H), 2.27–2.11 (m, 3H), 2.08 (s, 3H), 1.76–1.67 (m, 2H), 1.06–1.02 (m, 21H). ¹³C NMR (CDCl₃, 75 MHz): δ 205.9, 171.7, 165.5, 165.2, 138.2, 137.8, 137.8, 133.4, 133.3, 129.8, 129.5, 129.3, 128.5, 128.3, 127.8, 127.6, 127.6, 114.8, 106.1, 106.0, 105.7, 83.3, 82.1, 82.0, 81.6, 81.5, 72.3, 71.9, 66.8, 65.7, 65.6, 62.8, 37.6, 30.2, 29.7, 28.6, 27.5, 17.9, 11.9. IR (CHCl₃): ν_{\max} 2933, 2862, 1718, 1446, 1318, 1297, 1267, 1113, 1072, 1026 cm⁻¹. MALDI-HRMS calcd for C₆₉H₈₄O₁₈SiNa (*m/z*): [MNa⁺] 1251.5325, found 1251.5296.

The combined fractions of trisaccharide **46** containing some trichloroacetamide were dissolved in anhydrous CH₂Cl₂ (62 mL) and premixed pyridine (5.90 mL) and AcOH (3.60 mL), followed by hydrazine monohydrate (0.60 mL, 10.4 mmol), were added. The mixture was stirred at room temperature for 45 min and then quenched by the addition of acetone (3 mL) and stirred for 10 min. The solvents were evaporated, and the residue was purified by flash silica gel column chromatography (hexanes/EtOAc, 5:1) to give **47** (5.76 g, 82%, 2 steps) as a colorless oil. *R*_f = 0.25 (hexanes/EtOAc, 4:1). $[\alpha]_D = +82.6$ (c 0.93, CHCl₃). ¹H NMR (CDCl₃, 300 MHz): δ 8.04–7.96 (m, 6H), 7.60–7.51 (m, 3H), 7.44–7.39 (m, 6H), 7.34–7.18 (m, 10H), 5.88–5.74 (m, 1H), 5.39 (s, 1H), 5.38 (s, 1H), 5.27 (s, 1H), 5.25 (s, 1H), 5.13 (s, 1H), 5.04–4.92

(m, 2H), 5.02 (d, $J = 2.5$ Hz, 1H), 4.79 (d, $J = 11.9$ Hz, 1H), 4.65 (d, $J = 11.9$ Hz, 1H), 4.61 (d, $J = 11.9$ Hz, 1H), 4.48 (d, $J = 11.9$ Hz, 1H), 4.35–4.30 (m, 1H), 4.19–4.13 (m, 3H), 4.02–3.71 (m, 8H), 3.64 (dd, $J = 3.4, 11.0$ Hz, 1H), 3.47 (td, $J = 6.3, 9.6$ Hz, 1H), 2.96 (d, $J = 5.3$ Hz, 1H), 2.18–2.10 (m, 2H), 1.76–1.67 (m, 2H), 1.12–0.98 (m, 21H). ^{13}C NMR (CDCl_3 , 75 MHz): δ 166.4, 165.3, 165.1, 138.1, 137.7, 137.5, 133.4, 133.3, 133.2, 129.6, 129.4, 129.3, 129.0, 128.4, 128.2, 127.7, 127.6, 114.7, 106.1, 105.9, 105.1, 85.7, 84.7, 83.3, 83.2, 82.1, 81.8, 81.6, 81.4, 72.3, 72.1, 66.8, 65.7, 62.9, 30.3, 28.7, 18.0, 12.0. IR (CHCl_3): ν_{max} 2942, 2868, 1721, 1452, 1316, 1300, 1269, 1114, 1070, 1028 cm^{-1} . MALDI-HRMS calcd for $\text{C}_{64}\text{H}_{78}\text{O}_{16}\text{SiNa}$ (m/z): $[\text{MNa}^+]$ 1153.4957, found 1153.4932.

Pent-4-enyl 5-O-(5-O-(2-O-Benzoyl-3-O-(2-O-benzoyl-3-O-benzyl-5-O-triisopropylsilyl- α -D-arabinofuranosyl)-5-O-triisopropylsilyl- α -D-arabinofuranosyl)-2-O-benzoyl-3-O-benzyl- α -D-arabinofuranoside (48). Trisaccharide **47** (5.76 g, 5.09 mmol) and imidate **12a** (4.31 g, 6.68 mmol) were coevaporated with anhydrous toluene (5×25 mL) and dried under vacuum overnight. The mixture was dissolved in anhydrous CH_2Cl_2 (100 mL) and cooled to -40 °C, and TMSOTf (0.13 mL, 0.675 mmol) was added. After 20 min at -40 to -30 °C, the suspension was treated with Et_3N , the solution was stirred for 15 min at room temperature, and the solvents were evaporated. Purification by flash silica gel column chromatography (hexanes/EtOAc, 7:1) gave tetrasaccharide **48** (7.14 g, 87%) as a colorless oil. $R_f = 0.40$ (hexanes/EtOAc, 5:1). $[\alpha]_{\text{D}} = +74.5$ (c 0.99, CHCl_3). ^1H NMR (CDCl_3 , 300 MHz): δ 8.12–8.02 (m, 8H), 7.62–7.54 (m, 4H), 7.47–7.18 (m, 23H), 5.92–7.79 (m, 1H), 5.53–5.52 (m, 2H), 5.45 (s, 2H), 5.43 (s, 1H), 5.32 (s, 1H), 5.31 (s, 1H), 5.19 (s, 1H), 5.10–4.97 (m, 2H), 4.84 (d, $J = 12.1$ Hz, 1H), 4.78 (d, $J = 12.1$ Hz, 1H), 4.70 (d, $J = 11.9$ Hz, 1H), 4.67 (d, $J = 12.1$ Hz, 1H), 4.61–4.56 (m, 3H), 4.42–4.17 (m, 7H), 4.03–3.72 (m, 9H), 3.52 (dt, $J = 6.4, 9.4$ Hz, 1H), 2.23–2.16 (m, 2H), 1.81–1.72 (m, 2H), 1.15–0.95 (m, 42H). ^{13}C NMR (CDCl_3 , 75 MHz): δ 165.5, 165.3, 165.1, 138.2, 137.9, 133.1, 129.8, 129.7, 129.5, 128.4, 128.2, 127.8, 127.6, 127.5, 114.7, 106.2, 106.0, 105.0, 84.1, 83.4, 83.1, 82.8, 82.2, 82.1, 81.9, 81.5, 78.7, 72.3, 72.1, 66.8, 65.8, 65.5, 62.5, 62.3, 30.2, 28.7, 17.9, 12.0, 11.9. IR (CHCl_3): ν_{max} 2943, 2867, 1722, 1452, 1316, 1299, 1268, 1115, 1070, 1028 cm^{-1} . MALDI-HRMS calcd for $\text{C}_{92}\text{H}_{116}\text{O}_{21}\text{Si}_2\text{Na}$ (m/z): $[\text{MNa}^+]$ 1635.7445, found 1635.7479.

Pent-4-enyl 5-O-(5-O-(2-O-Benzoyl-3-O-(2-O-benzoyl-3-O-benzyl- α -D-arabinofuranosyl)- α -D-arabinofuranosyl)-2-O-benzoyl-3-O-benzyl- α -D-arabinofuranosyl)-2-O-benzoyl-3-O-benzyl- α -D-arabinofuranoside (49). Tetrasaccharide **48** (5.20 g, 3.22 mmol) was dissolved in anhydrous $\text{MeOH}/\text{CH}_2\text{Cl}_2$ (4:1, 50 mL) and cooled to 0 °C, and AcCl (2.30 mL, 32.2 mmol) was added. The solution was stirred for 4 h, while slowly warming to room temperature. The reaction was quenched by addition of saturated aqueous NaHCO_3 solution (100 mL), and the aqueous layer was extracted with CH_2Cl_2 (4×100 mL). The combined organic extracts were dried over Na_2SO_4 , filtered, and evaporated. Purification by gradient flash silica gel column chromatography (hexanes/EtOAc, 3:1 to 1:2) gave **49** (3.65 g, 87%) as a colorless solid. $R_f = 0.10$ (hexanes/EtOAc, 1:1). $[\alpha]_{\text{D}} = +99.8$ (c 0.91, CHCl_3). ^1H NMR (CDCl_3 , 300 MHz): δ 8.07–7.97 (m, 8H), 7.61–7.52 (m, 3H), 7.47–7.15 (m, 24H), 5.89–5.76 (m, 1H), 5.50 (s, 1H), 5.46 (s, 1H), 5.40 (s, 1H), 5.35 (s, 2H), 5.29 (s, 1H), 5.27 (s, 1H), 5.14 (s, 1H), 5.03 (d, $J = 17.1$ Hz, 1H), 4.96 (d, $J = 10.7$ Hz, 1H), 4.80 (d, $J = 12.1$ Hz, 1H), 4.74 (d, $J = 12.1$ Hz, 1H), 4.68 (d, $J = 12.1$ Hz, 1H), 4.63 (d, $J = 12.1$ Hz, 1H), 4.53 (d, $J = 11.9$ Hz, 1H), 4.52 (d, $J = 11.9$ Hz, 1H), 4.39–4.33 (m, 2H), 4.27–4.23 (m, 1H), 4.18–4.09 (m, 4H), 3.98–3.67 (m, 9H), 3.62–3.54 (m, 1H), 3.48 (td, $J = 6.5, 9.6$ Hz, 1H), 2.21–2.12 (m, 2H), 2.03 (dd, $J = 4.4, 8.5$ Hz, 1H), 1.98 (dd, $J = 4.9, 7.6$ Hz, 1H), 1.77–1.68 (m, 2H). ^{13}C NMR (CDCl_3 , 75 MHz): δ 165.5, 165.3, 165.2, 165.0, 138.2, 137.8, 137.7, 137.4, 133.3, 133.2, 129.7, 129.4, 129.3, 128.4, 128.3, 128.2, 127.8, 127.7, 127.6, 127.5, 114.8, 106.1, 106.0, 105.9, 105.2, 83.6, 83.3, 83.2, 82.9, 82.6, 82.5, 82.1, 81.8, 81.7, 81.4, 79.5,

72.3, 72.2, 66.7, 65.7, 65.6, 61.9, 61.4, 30.1, 28.5. IR (CHCl_3): ν_{max} 3015, 1723, 1452, 1316, 1298, 1268, 1114, 1070, 1028 cm^{-1} . MALDI-HRMS calcd for $\text{C}_{74}\text{H}_{76}\text{O}_{21}\text{Na}$ (m/z): $[\text{MNa}^+]$ 1323.4777, found 1323.4745.

Pent-4-enyl 5-O-(5-O-(2-O-Benzoyl-3,5-di-O-benzyl- α -D-arabinofuranosyl)-2-O-benzoyl-3-O-(5-O-(2-O-benzoyl-3,5-di-O-benzyl- α -D-arabinofuranosyl)-2-O-benzoyl-3-O-benzyl- α -D-arabinofuranosyl)- α -D-arabinofuranosyl)-2-O-benzoyl-3-O-benzyl- α -D-arabinofuranoside (4). Tetrasaccharide **49** (0.800 g, 0.615 mmol) and imidate **10** (1.12 g, 1.93 mmol) were coevaporated with anhydrous toluene (3×15 mL) and dried in vacuo overnight. The mixture was dissolved in anhydrous CH_2Cl_2 (13 mL) and cooled to -40 °C, and TMSOTf (0.16 mL, 0.083 mmol) was added. After 35 min at -40 to -30 °C, the suspension was treated with Et_3N and the solution stirred for 15 min at room temperature before the solvents were evaporated. Purification by gradient flash silica gel column chromatography (hexanes/EtOAc, 5:1 to 3:1) gave hexasaccharide **4** (1.20 g, 92%) as a colorless foam. $R_f = 0.15$ (hexanes/EtOAc, 3:1). $[\alpha]_{\text{D}} = +96.3$ (c 0.90, CHCl_3). ^1H NMR (CDCl_3 , 300 MHz): δ 8.05–7.89 (m, 12H), 7.57–7.09 (m, 53H), 5.87–5.74 (m, 1H), 5.48 (s, 1H), 5.44 (d, $J = 1.5$ Hz, 1H), 5.39 (d, $J = 1.3$ Hz, 1H), 5.38–5.37 (m, 3H), 5.30 (s, 1H), 5.29 (d, $J = 1.2$ Hz, 1H), 5.26 (s, 1H), 5.24 (s, 1H), 5.16 (s, 1H), 5.11 (s, 1H), 5.05–4.97 (m, 1H), 4.96–4.91 (m, 1H), 4.76 (d, $J = 12.0$ Hz, 1H), 4.71 (d, $J = 11.9$ Hz, 1H), 4.63 (d, $J = 11.9$ Hz, 1H), 4.60 (d, $J = 12.0$ Hz, 1H), 4.58 (d, $J = 12.5$ Hz, 1H), 4.53–4.14 (m, 18H), 4.09–4.04 (m, 1H), 4.00–3.39 (m, 16H), 2.17–2.10 (m, 2H), 1.75–1.66 (m, 2H). ^{13}C NMR (CDCl_3 , 75 MHz): δ 165.5, 165.3, 165.2, 165.1, 138.2, 138.0, 137.9, 137.8, 137.7, 133.2, 133.1, 129.8, 129.7, 129.6, 129.5, 128.4, 128.3, 128.2, 127.8, 127.7, 127.6, 127.5, 127.4, 114.7, 106.1, 106.0, 105.3, 83.3, 83.3, 83.2, 82.6, 82.4, 82.2, 81.9, 81.8, 81.7, 81.5, 79.9, 73.3, 72.3, 72.2, 71.8, 69.2, 66.8, 65.7, 65.5, 65.3, 65.0, 30.2, 28.6. IR (CHCl_3): ν_{max} 3003, 2923, 1722, 1452, 1316, 1299, 1268, 1115, 1071, 1027 cm^{-1} . MALDI-HRMS calcd for $\text{C}_{126}\text{H}_{124}\text{O}_{31}\text{Na}$ (m/z): $[\text{MNa}^+]$ 2156.8058, found 2156.8005.

1-O-(5-O-(5-O-(5-O-(2-O-Benzoyl-3,5-di-O-benzyl- α -D-arabinofuranosyl)-2-O-benzoyl-3-O-(5-O-(2-O-benzoyl-3,5-di-O-benzyl- α -D-arabinofuranosyl)-2-O-benzoyl-3-O-benzyl- α -D-arabinofuranosyl)- α -D-arabinofuranosyl)-2-O-benzoyl-3-O-benzyl- α -D-arabinofuranosyl)-2-O-benzoyl-3-O-benzyl- α -D-arabinofuranosyl) Trichloroacetimidate (5). To a solution of hexasaccharide **4** (0.250 g, 0.117 mmol) in acetonitrile (8.0 mL) and water (0.5 mL) was added NBS (0.063 g, 0.35 mmol), and the solution was stirred at room temperature for 1.5 h. After MS analysis showed complete conversion (ca. 1–1.5 h), the reaction was quenched by addition of aqueous $\text{Na}_2\text{S}_2\text{O}_3$ solution (5 mL), water (5 mL), and brine (5 mL). The aqueous phase was extracted with EtOAc (4×20 mL). The combined organic extracts were dried over MgSO_4 , filtered, and concentrated. Purification by gradient flash silica gel column chromatography (hexanes/EtOAc, 2:1 to 1:1) gave the corresponding lactol as a mixture with the halohydrin byproduct, $R_f = 0.25$ (hexanes/EtOAc, 3:2). The mixture was dissolved in anhydrous CH_2Cl_2 (1.5 mL) and cooled to 0 °C. Trichloroacetonitrile (0.11 mL, 1.11 mmol) followed by DBU (0.0025 mL, 0.016 mmol) were added. After 30 min at 0 °C, the mixture was filtered over a plug of silica gel and washed with CH_2Cl_2 , and the solvents were evaporated. Purification by gradient flash silica gel column chromatography (hexanes/EtOAc, 3:1 to 2:1) gave **5** (0.177 g, 72%, 2 steps) as a colorless foam. $R_f = 0.30$ (hexanes/EtOAc, 2:1). $[\alpha]_{\text{D}} = +66.7$ (c 1.07, CHCl_3). ^1H NMR (CDCl_3 , 300 MHz): δ 8.65 (s, 1H), 8.16–7.98 (m, 12H), 7.65–7.18 (m, 53H), 6.55 (s, 1H), 5.75 (d, $J = 1.3$ Hz, 1H), 5.57 (s, 1H), 5.49–5.45 (m, 4H), 5.39 (s, 1H), 5.38 (d, $J = 1.2$ Hz, 1H), 5.34 (s, 1H), 5.30 (s, 1H), 5.25 (s, 1H), 4.91 (d, $J = 11.9$ Hz, 1H), 4.79 (d, $J = 11.9$ Hz, 1H), 4.72 (d, $J = 11.9$ Hz, 1H), 4.68–3.48 (m, 35H). ^{13}C NMR (CDCl_3 , 75 MHz): δ 165.3, 165.1, 160.8, 138.0, 137.9, 137.7, 133.5, 133.2, 133.1, 129.9, 129.8, 129.7, 129.6, 129.5, 129.4, 129.1, 128.6, 128.4,

128.3, 128.2, 127.8, 127.7, 127.6, 127.5, 127.4, 106.3, 106.1, 105.3, 103.9, 91.1, 84.6, 83.3, 83.2, 83.1, 82.8, 82.6, 82.4, 82.3, 82.2, 82.0, 81.9, 81.7, 81.5, 80.8, 79.8, 73.3, 72.2, 71.8, 69.2, 65.5, 65.3, 65.0. IR (CHCl₃): ν_{\max} 1723, 1452, 1316, 1298, 1268, 1115, 1071, 1027 cm⁻¹. MALDI-HRMS calcd for C₁₂₃H₁₁₆Cl₃NO₃₁Na (*m/z*): [MNa⁺] 2230.6495, found 2230.6432.

6-(Benzylthio)hexyl 5-O-(5-O-(5-O-(2-O-Benzoyl-3,5-di-O-benzyl- α -D-arabinofuranosyl)-2-O-benzoyl-3-O-(5-O-(2-O-benzoyl-3,5-di-O-benzyl- α -D-arabinofuranosyl)-2-O-benzoyl-3-O-benzyl- α -D-arabinofuranosyl)- α -D-arabinofuranosyl)-2-O-benzoyl-3-O-benzyl- α -D-arabinofuranosyl)-2-O-benzoyl- α -D-arabinofuranoside (50). Imidate **5** (0.030 g, 0.0136 mmol) and 6-(benzylthio)hexan-1-ol (0.0061 g, 0.0271 mmol) were coevaporated with anhydrous toluene (4 × 5 mL) and dried in vacuo overnight. The mixture was dissolved in anhydrous CH₂Cl₂ (0.3 mL) and cooled to -20 °C, and TMSOTf (0.39 mL of a 0.052 M solution in CH₂Cl₂, 0.002 mmol) was added. After 30 min, the reaction was quenched with Et₃N, the solution was stirred for 15 min at room temperature, and the solvents were evaporated. Pyridine (4 mL) and acetic anhydride (2 mL) were added, and the mixture was stirred at room-temperature overnight. The solvents were evaporated, and the residue was purified by flash silica gel column chromatography (toluene/EtOAc, 9:1) to afford **50** (0.203 g, 66%) and α/β -**50** (0.0038 g, 12%, α/β = 1:1) as colorless oils. **50**: R_f = 0.35 (toluene/EtOAc, 9:1). [α]_D = +84.5 (*c* 0.44, CHCl₃). ¹H NMR (CDCl₃, 500 MHz): δ 8.04–7.89 (m, 12H), 7.54–7.09 (m, 58H), 5.47 (s, 1H), 5.44 (d, *J* = 1.6 Hz, 1H), 5.39 (d, *J* = 1.2 Hz, 1H), 5.37–5.36 (m, 3H), 5.29 (s, 1H), 5.28 (d, *J* = 1.1 Hz, 1H), 5.25 (s, 1H), 5.22 (s, 1H), 5.15 (s, 1H), 5.10 (s, 1H), 4.75 (d, *J* = 12.0 Hz, 1H), 4.70 (d, *J* = 11.9 Hz, 1H), 4.62 (d, *J* = 12.0 Hz, 1H), 4.59 (d, *J* = 12.1 Hz, 1H), 4.57 (d, *J* = 12.5 Hz, 1H), 4.54–4.26 (m, 13H), 4.22–4.19 (m, 2H), 4.15–4.14 (m, 2H), 4.08–4.05 (m, 1H), 3.98–3.82 (m, 6H), 3.77 (dd, *J* = 2.5, 11.6 Hz, 1H), 3.72–3.65 (m, 5H), 3.67 (s, 2H), 3.58 (dd, *J* = 3.7, 10.7 Hz, 1H), 3.53–3.47 (m, 2H), 3.44–3.40 (m, 2H), 2.38 (t, *J* = 7.5 Hz, 2H), 1.60–1.50 (m, 4H), 1.35–1.31 (m, 4H). ¹³C NMR (CDCl₃, 125 MHz): δ 165.5, 165.3, 165.2, 165.1, 138.7, 138.0, 137.9, 137.8, 137.7, 133.2, 133.1, 133.1, 129.9, 129.8, 129.7, 129.6, 129.5, 128.8, 128.5, 128.4, 128.3, 128.2, 127.9, 127.8, 127.7, 127.6, 127.5, 127.4, 126.8, 106.2, 106.1, 106.0, 105.4, 83.3, 83.2, 82.6, 82.4, 82.3, 82.2, 81.9, 81.7, 81.6, 81.5, 79.9, 73.3, 72.4, 72.3, 72.2, 71.8, 69.3, 69.2, 67.4, 65.7, 65.5, 65.3, 65.1, 36.3, 31.3, 29.3, 29.2, 28.6, 25.7. IR (CHCl₃): ν_{\max} 3008, 2928, 1722, 1452, 1316, 1299, 1268, 1115, 1071, 1027 cm⁻¹. MALDI-HRMS calcd for C₁₃₄H₁₃₄O₃₁SNa (*m/z*): [MNa⁺] 2295.8595, found 2295.8578. **β -50**: R_f = 0.20 (toluene/EtOAc, 9:1). ¹H NMR (CDCl₃, 500 MHz) only characteristic signals for the β -anomer are given: δ 5.49 (s, 1H), 5.45 (d, *J* = 1.7 Hz, 1H), 5.40 (d, *J* = 1.7 Hz, 1H), 5.39 (s, 1H), 5.38 (s, 1H), 5.29–5.28 (m, 4H), 5.19 (s, 1H), 5.15 (s, 1H), 5.13 (dd, *J* = 4.6 (β), 6.4 Hz, 1H), 2.18 (t, *J* = 7.5 Hz, 2H). MALDI-HRMS calcd for C₁₃₄H₁₃₄O₃₁SNa (*m/z*): [MNa⁺] 2295.8595, found 2295.8593.

6-Thiohexyl 5-O-(5-O-(5-O-(α -D-arabinofuranosyl)-3-O-(5-O-(α -D-arabinofuranosyl)- α -D-arabinofuranosyl)- α -D-arabinofuranosyl)- α -D-arabinofuranosyl)- α -D-arabinofuranoside (15). A solution of hexasaccharide **50** (0.030 g, 0.013 mmol) in anhydrous THF (10 mL) was added dropwise to a dark blue solution of sodium in liquid ammonia at -78 °C over 10 min. The dark blue solution was stirred for 1 h and then quenched with MeOH. The ammonia was removed with a stream of nitrogen and the solution was then neutralized with Amberlite IR 120 resin. The resin was filtered, washed with MeOH and the filtrate was concentrated. The residue was purified by gradient reversed-phase C₁₈ column chromatography (MeOH/H₂O, 0:1 to 1:0) and freeze-dried to give **15** exclusively as the sulfur-linked dimer (0.0044 g, 37%) as a colorless amorphous solid. ¹H NMR (D₂O, 500 MHz): δ 5.11 (s, 2H), 5.01 (s, 2H), 4.97–4.96 (m, 6H), 4.90 (s, 2H), 4.21–3.58 (m, 62H), 3.47 (td, *J* = 6.3, 9.7 Hz, 2H), 2.67 (t, *J* = 7.0 Hz, 4H), 1.63–1.57 (m, 4H), 1.54–1.49 (m, 4H), 1.34–1.28 (m, 8H). ESI-HRMS calcd for C₇₂H₁₂₂O₅₀S₂Na₂ (*m/z*): [M2Na²⁺] 948.3115, found 948.3127.

Pent-4-enyl 5-O-(5-O-(5-O-(2-O-Benzoyl-3-O-benzyl- α -D-arabinofuranosyl)-2-O-benzoyl-3-O-(5-O-(2-O-benzoyl-3-O-benzyl- α -D-arabinofuranosyl)-2-O-benzoyl-3-O-benzyl- α -D-arabinofuranosyl)- α -D-arabinofuranosyl)-2-O-benzoyl-3-O-benzyl- α -D-arabinofuranoside (6). Tetrasaccharide **49** (0.500 g, 0.384 mmol) and imidate **12a** (0.743 g, 1.15 mmol) were coevaporated with anhydrous toluene (4 × 15 mL) and dried in vacuo overnight. The mixture was dissolved in CH₂Cl₂ (10 mL) and cooled to -40 °C, and TMSOTf (0.010 mL, 0.054 mmol) was added. After 15 min at -40 to -30 °C, the suspension was treated with Et₃N, the solution was stirred for 10 min at room temperature, and the solvents were evaporated. Purification by flash silica gel column chromatography (hexanes/EtOAc, 5:1) gave the corresponding hexasaccharide (0.836 g, 96%) as a colorless foam. R_f = 0.25 (hexanes/EtOAc, 4:1). [α]_D = +89.4 (*c* 0.95, CHCl₃). ¹H NMR (CDCl₃, 300 MHz): δ 8.07–7.97 (m, 12H), 7.59–7.12 (m, 43H), 5.89–5.76 (m, 1H), 5.49 (s, 1H), 5.47 (s, 1H), 5.44 (s, 1H), 5.40 (s, 3H), 5.33 (s, 1H), 5.30 (s, 1H), 5.29 (s, 1H), 5.26 (s, 1H), 5.14 (s, 2H), 5.03 (d, *J* = 17.1 Hz, 1H), 4.96 (d, *J* = 10.1 Hz, 1H), 4.79 (d, *J* = 12.0 Hz, 1H), 4.71 (d, *J* = 12.1 Hz, 1H), 4.65 (d, *J* = 12.1 Hz, 1H), 4.63 (s, 1H), 4.63 (d, *J* = 12.0 Hz, 1H), 4.55–4.49 (m, 5H), 4.40 (d, *J* = 12.1 Hz, 1H), 4.37–4.10 (m, 9H), 4.04–3.65 (m, 15H), 3.48 (td, *J* = 6.4, 9.7 Hz, 1H), 2.19–2.12 (m, 2H), 1.78–1.68 (m, 2H), 1.05–0.78 (m, 42H). ¹³C NMR (CDCl₃, 75 MHz): δ 165.5, 165.3, 165.1, 138.2, 137.9, 137.8, 133.2, 133.1, 133.0, 129.8, 129.7, 129.6, 129.5, 129.4, 128.4, 128.3, 128.2, 128.1, 128.0, 127.8, 127.7, 127.6, 127.5, 127.4, 127.3, 114.7, 106.2, 106.1, 105.9, 105.2, 83.9, 83.3, 83.2, 82.7, 82.5, 82.2, 82.0, 81.9, 81.7, 81.5, 79.9, 72.3, 72.1, 71.8, 66.7, 65.7, 65.5, 65.2, 65.0, 62.6, 62.5, 30.2, 28.6, 17.9, 17.8, 11.9, 11.8. IR (CHCl₃): ν_{\max} 2942, 2867, 1722, 1452, 1316, 1299, 1268, 1116, 1070, 1027 cm⁻¹. MALDI-HRMS calcd for C₁₃₀H₁₅₂O₃₁Si₂Na (*m/z*): [MNa⁺] 2288.9787, found 2288.9788.

The hexasaccharide (0.195 g, 0.086 mmol) was dissolved in anhydrous MeOH/CH₂Cl₂ (4:1, 2 mL) and cooled to 0 °C, and AcCl (0.061 mL, 0.85 mmol) was added. The solution was stirred for 7 h while slowly warming to room temperature. The reaction was quenched by addition of saturated aqueous NaHCO₃ solution (5 mL), and the aqueous layer was extracted with CH₂Cl₂ (5 × 5 mL). The combined organic extracts were washed with brine (20 mL), dried over Na₂SO₄, filtered, and evaporated. Purification by gradient flash silica gel column chromatography (hexanes/EtOAc, 2:1 to 1:1) gave **6** (0.157 g, 93%) as a colorless foam. R_f = 0.10 (hexanes/EtOAc, 1:1). [α]_D = +113.4 (*c* 0.92, CHCl₃). ¹H NMR (CDCl₃, 300 MHz): δ 8.15–8.02 (m, 12H), 7.67–7.21 (m, 43H), 5.97–5.83 (m, 1H), 5.56 (s, 1H), 5.54 (d, *J* = 1.5 Hz, 1H), 5.50 (d, *J* = 1.5 Hz, 1H), 5.48 (d, *J* = 1.6 Hz, 1H), 5.46 (d, *J* = 1.6 Hz, 2H), 5.41 (d, *J* = 1.5 Hz, 1H), 5.38 (s, 1H), 5.35 (s, 1H), 5.34 (s, 1H), 5.27 (s, 1H), 5.21 (s, 1H), 5.14–5.00 (m, 2H), 4.86 (d, *J* = 11.8 Hz, 1H), 4.82 (d, *J* = 10.9 Hz, 1H), 4.73 (d, *J* = 12.0 Hz, 1H), 4.71 (d, *J* = 12.2 Hz, 1H), 4.70 (d, *J* = 11.8 Hz, 1H), 4.65 (d, *J* = 12.5 Hz, 1H), 4.63 (d, *J* = 12.0 Hz, 1H), 4.60 (d, *J* = 12.5 Hz, 1H), 4.56–4.54 (m, 1H), 4.53 (d, *J* = 12.0 Hz, 1H), 4.50 (d, *J* = 12.2 Hz, 1H), 4.44–4.28 (m, 5H), 4.26–4.22 (m, 2H), 4.20–4.13 (m, 2H), 4.08–3.76 (m, 13H), 3.67–3.61 (m, 2H), 3.56 (td, *J* = 6.5, 9.8 Hz, 1H), 2.64 (br s, 1H), 2.27–2.19 (m, 2H), 1.88 (br s, 1H), 1.85–1.75 (m, 2H). ¹³C NMR (CDCl₃, 75 MHz): δ 165.5, 165.3, 165.2, 165.1, 165.0, 138.2, 138.0, 137.7, 137.5, 137.4, 133.3, 133.2, 133.1, 129.7, 129.6, 129.5, 129.4, 129.3, 128.4, 128.3, 128.2, 127.8, 127.7, 127.6, 127.5, 114.7, 106.2, 106.1, 106.0, 105.9, 105.5, 83.6, 83.5, 83.3, 83.2, 82.9, 82.8, 82.7, 82.2, 82.0, 81.9, 81.8, 81.7, 81.5, 80.1, 72.3, 72.2, 71.9, 66.7, 65.9, 65.7, 65.6, 65.0, 62.1, 61.9, 30.1, 28.6. IR (CHCl₃): ν_{\max} 3008, 2932, 1723, 1452, 1316, 1298, 1268, 1114, 1071, 1027 cm⁻¹. MALDI-HRMS calcd for C₁₁₂H₁₁₂O₃₁Na (*m/z*): [MNa⁺] 1976.7119, found 1976.7150.

Docamer 51. Hexamannoside **3** (0.020 g, 6.96 μ mol) and imidate **5** (0.038 g, 17.2 μ mol) were coevaporated with anhydrous toluene (4 × 2 mL) and dried in vacuo overnight. The mixture was dissolved in Et₂O (0.15 mL) and cooled to 0 °C, and TBSOTf

(0.032 mL of a 0.044 M solution in Et₂O, 1.4 μmol) was added. After 30 min, the reaction was quenched with Et₃N, the mixture was stirred at room temperature for 15 min, and the solvents were evaporated. Purification by gradient flash silica gel column chromatography (hexanes/EtOAc, 2:1 to 1:1) gave dodecasaccharide **51** (0.024 g, 70%) as a colorless foam. $R_f = 0.17$ (hexanes/EtOAc, 3:2). $[\alpha]_D = +57.9$ (*c* 0.56, CHCl₃). ¹H NMR (CDCl₃, 500 MHz): δ 8.11–6.92 (m, 160H), 5.83–5.82 (m, 1H), 5.74–5.73 (m, 1H), 5.70–5.69 (m, 2H), 5.61–5.60 (m, 1H), 5.53 (s, 1H), 5.45 (s, 1H), 5.42 (d, *J* = 1.3 Hz, 1H), 5.37 (d, *J* = 1.3 Hz, 1H), 5.33 (d, *J* = 1.5 Hz, 1H), 5.32 (d, *J* = 1.3 Hz, 1H), 5.28 (s, 1H), 5.27 (d, *J* = 1.2 Hz, 1H), 5.22 (s, 1H), 5.17 (s, 1H), 5.13 (s, 1H), 5.09 (d, *J* = 1.6 Hz, 1H), 5.07 (d, *J* = 1.8 Hz, 1H), 5.03 (d, *J* = 1.6 Hz, 1H), 5.00 (d, *J* = 1.2 Hz, 1H), 4.89 (s, 1H), 4.86–3.30 (m, 103H), 2.36 (t, *J* = 7.4 Hz, 2H), 1.52–1.46 (m, 4H), 1.34–1.23 (m, 4H). ¹³C NMR (CDCl₃, 125 MHz): δ 165.8, 165.5, 165.3, 165.2, 165.1, 139.1, 139.0, 138.7, 138.4, 138.3, 138.2, 138.0, 137.9, 137.8, 137.7, 133.2, 133.1, 133.0, 132.8, 132.6, 130.3, 130.1, 130.0, 129.9, 129.8, 129.7, 129.6, 129.5, 128.8, 128.6, 128.5, 128.4, 128.3, 128.2, 128.1, 128.0, 127.8, 127.7, 127.6, 127.5, 127.4, 127.3, 127.2, 126.9, 126.8, 106.7, 106.2, 106.1, 106.0, 105.3, 99.8, 99.3, 98.2, 98.1, 97.9, 83.3, 83.2, 82.9, 82.6, 82.5, 82.4, 82.3, 82.1, 81.9, 81.7, 81.6, 80.9, 80.4, 79.8, 79.6, 78.6, 78.1, 75.5, 75.3, 75.2, 75.0, 74.8, 74.7, 74.5, 74.2, 73.8, 73.3, 73.2, 72.3, 72.1, 71.8, 71.7, 71.6, 71.5, 71.4, 71.3, 71.1, 71.0, 70.9, 69.3, 69.2, 69.1, 69.0, 68.9, 68.8, 68.7, 67.8, 67.0, 65.8, 65.7, 65.4, 65.3, 65.0, 64.7, 36.3, 31.3, 29.3, 29.1, 28.7, 25.8. IR (CHCl₃): ν_{\max} 3008, 2928, 1722, 1452, 1268, 1115, 1028 cm⁻¹. MALDI-HRMS for C₂₉₆H₂₉₄O₆₅SNa (*m/z*): [MNa⁺] 4944.9368, found 4944.9151.

Dodecamer 1. Dodecasaccharide **51** (0.030 g, 0.0061 mmol) was dissolved in anhydrous MeOH/CH₂Cl₂ (1:1, 0.8 mL), and NaOMe (0.003 g, 0.056 mmol) was added. After 5 d at room temperature, the solvents were evaporated and the residue was passed through a short plug of silica gel (hexanes/EtOAc, 1:1 to 0:1) to remove the methyl benzoate. The residue was dissolved in anhydrous THF (10 mL), and this solution was added dropwise over 10 min to a dark blue solution of sodium in liquid ammonia at –78 °C. The dark blue solution was stirred for 1 h and then quenched with MeOH, and small pieces of sodium were added to the mixture until the blue color of the solution persisted. After 1 h, the reaction was quenched with MeOH and the ammonia was removed with a stream of nitrogen. The solution was neutralized with Amberlite IR 120 resin. The resin was filtered and washed with MeOH, and the filtrate was concentrated. The residue was purified by gradient reversed-phase C₁₈ column chromatography (MeOH/H₂O, 0:1 to 1:0) and freeze-dried to give **1** exclusively as the sulfur-linked dimer (0.006 g, 52% over 2 steps) as a colorless amorphous solid. ¹H NMR (D₂O, 500 MHz): δ 5.07 (s, 2H), 5.05 (s, 2H), 5.02 (s, 2H), 5.01 (s, 2H), 4.97 (s, 6H), 4.93 (s, 2H), 4.91 (s, 2H), 4.80 (s, 2H), 4.78 (s, 2H), 4.74 (s, 2H), 4.21–4.18 (m, 4H), 4.12–3.53 (m, 130H), 3.49–3.44 (m, 2H), 2.67 (t, *J* = 7.1 Hz, 4H), 1.64–1.58 (m, 4H), 1.57–1.50 (m, 4H), 1.37–1.27 (m, 8H). ESI-HRMS calcd for C₁₄₄H₂₄₂O₁₁₀S₂Na₃ (*m/z*): [M3Na³⁺] 1288.4170, found 1288.4159.

1-O-(3,4,6-Tri-O-Benzyl-2-O-levulinoyl-α/β-D-mannopyranosyl) Trichloroacetimidate (52). To a solution of allyl 3,4,6-tri-*O*-benzyl-α/β-D-mannopyranoside⁴⁶ (2.07 g, 4.22 mmol) in anhydrous CH₂Cl₂ (26 mL) were added DMAP (0.774 g, 6.34 mmol) and DIPC (0.99 mL, 6.3 mmol) at 0 °C. After 5 min at 0 °C, levulinic acid (0.71 mL, 6.7 mmol) was added, and the mixture was stirred at room temperature for 2 h. The suspension was diluted with hexanes/EtOAc (1:1), filtered over a plug of silica gel, and washed with hexanes/EtOAc (1:1), and the solvents were evaporated. Purification by flash silica gel column chromatography (hexanes/EtOAc, 1:1) gave allyl 3,4,6-tri-*O*-benzyl-2-*O*-levulinoyl-α/β-D-mannopyranoside (2.28 g, 92%, α/β = 94:6) as a colorless oil. $R_f = 0.30$ (hexanes/EtOAc, 2:1). $[\alpha]_D = +21.9$ (*c* 1.23, CHCl₃).

¹H NMR (CDCl₃, 300 MHz): δ 7.40–7.17 (m, 15H), 5.95–5.82 (m, 1H), 5.41 (dd, *J* = 1.8, 3.3 Hz, 1H), 5.31–5.18 (m, 2H), 4.90 (s, 1H), 4.88 (d, *J* = 12.3 Hz, 1H), 4.71 (d, *J* = 11.2 Hz, 1H), 4.79 (d, *J* = 12.3 Hz, 1H), 4.56–4.49 (m, 3H), 4.21–4.14 (m, 1H), 4.04–3.68 (m, 6H), 2.79–2.68 (m, 4H), 2.14 (s, 3H). ¹³C NMR (CDCl₃, 75 MHz): δ 206.2, 172.0, 138.3, 138.2, 138.0, 133.4, 128.3, 128.0, 127.9, 127.7, 127.6, 127.5, 117.6, 96.8, 78.1, 75.1, 74.3, 73.3, 71.6, 71.3, 68.8, 68.1, 37.9, 29.7, 28.1. IR (CHCl₃): ν_{\max} 3008, 1737, 1720, 1454, 1363, 1137, 1087, 1028 cm⁻¹. MALDI-HRMS calcd for C₃₅H₄₀O₈Na (*m/z*): [MNa⁺] 611.2621, found 611.2604. 3,4,6-Tri-*O*-benzyl-2-*O*-levulinoyl-α/β-D-mannopyranoside (1.22 g, 2.09 mmol) was dissolved in anhydrous MeOH (35 mL), and PdCl₂ (0.111 g, 0.626 mmol) was added. After 8 h at room temperature the suspension was filtered over Celite and washed with CH₂Cl₂, and the solvents were evaporated. The residue was dissolved in hexanes/EtOAc (1:1), filtered over a plug of silica gel, eluted with hexanes/EtOAc (1:1), and concentrated in vacuo. Purification by gradient flash silica gel column chromatography (hexanes/EtOAc, 2:1 to 1:1) gave the corresponding lactol (0.958 g, 84%) as a colorless oil. $R_f = 0.28$ (hexanes/EtOAc, 1:1). The lactol (0.800 g, 1.46 mmol) was dissolved in anhydrous CH₂Cl₂ (24 mL) and cooled to 0 °C, and trichloroacetoneitrile (2.90 mL, 28.9 mmol) followed by DBU (0.033 mL, 0.22 mmol) were added. After 30 min at 0 °C, the mixture was filtered over a plug of silica gel and eluted with EtOAc and CH₂Cl₂, and the solvents were removed under reduced pressure. Purification by flash silica gel column chromatography (hexanes/EtOAc, 2:1) gave **52** (0.857 g, 85%, α/β = 95:5) as a colorless oil. $R_f = 0.30$ (hexanes/EtOAc, 2:1). $[\alpha]_D = +36.9$ (*c* 0.84, CHCl₃). ¹H NMR (CDCl₃, 300 MHz): δ 8.72 (s, 1H), 7.39–7.21 (m, 15H), 6.32 (d, *J* = 2.1 Hz, 1H), 5.52 (t, *J* = 2.1 Hz, 1H), 4.91 (d, *J* = 10.7 Hz, 1H), 4.76 (d, *J* = 11.3 Hz, 1H), 4.70 (d, *J* = 12.0 Hz, 1H), 4.60 (d, *J* = 11.3 Hz, 1H), 4.58 (d, *J* = 10.7 Hz, 1H), 4.54 (d, *J* = 12.0 Hz, 1H), 4.07–4.03 (m, 3H), 3.88 (dd, *J* = 3.2, 11.1 Hz, 1H), 3.75 (dd, *J* = 1.4, 11.1 Hz, 1H), 2.76 (br s, 4H), 2.16 (s, 3H). ¹³C NMR (CDCl₃, 75 MHz): δ 206.0, 171.7, 159.8, 138.1, 138.0, 137.5, 128.3, 128.2, 128.0, 127.8, 127.7, 127.5, 95.2, 90.7, 77.1, 75.3, 74.2, 73.5, 73.3, 71.8, 68.3, 67.4, 37.8, 29.7, 28.0. IR (CHCl₃): ν_{\max} 3008, 1743, 1720, 1675, 1363, 1155, 1102, 1028 cm⁻¹. MALDI-HRMS calcd for C₃₄H₃₆Cl₃NO₈Na (*m/z*): [MNa⁺] 714.1399, found 714.1401.

Pent-4-enyl 5-O-(5-O-(5-O-(2-O-Benzoyl-3-O-benzyl-5-O-(3,4,6-tri-O-benzyl-2-O-levulinoyl-α-D-mannopyranosyl)-α-D-arabinofuranosyl)-2-O-benzoyl-3-O-(5-O-(2-O-benzoyl-3-O-benzyl-5-O-(3,4,6-tri-O-benzyl-2-O-levulinoyl-α-D-mannopyranosyl)-α-D-arabinofuranosyl)-2-O-benzoyl-3-O-benzyl-α-D-arabinofuranosyl)-2-O-benzoyl-3-O-benzyl-α-D-arabinofuranosyl) (53). Hexasaccharide **6** (0.400 g, 0.205 mmol) and imidate **52** (0.710 g, 1.02 mmol) were coevaporated with anhydrous toluene (3 × 20 mL) and dried in vacuo overnight. The mixture was dissolved in Et₂O (6.5 mL) and cooled to 0 °C, and TBSOTf (0.0094 mL, 0.042 mmol) was added. After 30 min at 0 °C, the reaction was quenched with Et₃N and stirred at room temperature for 10 min, and the solvents were evaporated. Purification by recycling preparative HPLC (Japan Analytical Industry, JAIGEL-2H and 2.5H, CHCl₃) gave a mixture (0.426 g, >68%) of the desired octasaccharide **53** together with small amounts of the heptasaccharide. The mixture was dissolved in anhydrous DMF (2 mL), and imidazole (0.050 g) followed by TIPSCl (0.063 mL) were added. The solution was stirred at room temperature overnight. Water was added, and the aqueous phase was extracted with EtOAc. The combined organic extracts were washed with water and brine, dried over MgSO₄, filtered, and evaporated. Purification by gradient flash silica gel column chromatography (hexanes/EtOAc, 2:1 to 3:2) gave octasaccharide **53** (0.183 g, 30%, 2 steps) as a colorless oil. $R_f = 0.15$ (hexanes/EtOAc, 3:2). $[\alpha]_D = +84.6$ (*c* 0.24, CHCl₃). ¹H NMR (CDCl₃, 300 MHz): δ 8.04–7.95 (m, 12H), 7.53–7.03 (m, 73H), 5.84–5.76 (m, 1H), 5.49 (s, 1H), 5.44 (d, *J* = 1.6 Hz, 1H), 5.38–5.37 (m, 3H), 5.37 (d, *J* = 1.5 Hz, 1H), 5.34 (dd, *J* = 1.8, 3.2 Hz,

(46) Goddat, J.; Grey, A. A.; Hricovini, M.; Grushcow, J.; Carver, J. P.; Shah, R. N. *Carbohydr. Res* **1994**, *252*, 159–170.

1H), 5.29 (s, 1H), 5.29 (dd, $J = 2.0, 3.6$ Hz, 1H), 5.27 (d, $J = 1.2$ Hz, 1H), 5.25 (s, 1H), 5.23 (s, 1H), 5.08 (s, 1H), 5.06 (s, 1H), 4.98–4.94 (m, 1H), 4.90–4.87 (m, 1H), 4.80 (d, $J = 1.6$ Hz, 1H), 4.75 (d, $J = 1.7$ Hz, 1H), 4.77 (d, $J = 10.9$ Hz, 1H), 4.76 (d, $J = 10.8$ Hz, 1H), 4.76 (d, $J = 12.7$ Hz, 1H), 4.69 (d, $J = 12.2$ Hz, 1H), 4.65 (d, $J = 12.2$ Hz, 1H), 4.63 (d, $J = 11.1$ Hz, 1H), 4.61 (d, $J = 11.7$ Hz, 1H), 4.61 (d, $J = 12.2$ Hz, 1H), 4.60 (d, $J = 12.1$ Hz, 1H), 4.52 (d, $J = 12.0$ Hz, 1H), 4.52 (d, $J = 11.9$ Hz, 1H), 4.48–4.42 (m, 7H), 4.34–4.13 (m, 11H), 4.10 (d, $J = 10.9$ Hz, 1H), 4.05 (d, $J = 10.9$ Hz, 1H), 3.95–3.89 (m, 4H), 3.86–3.52 (m, 21H), 3.48–3.43 (m, 2H), 2.68–2.61 (m, 8H), 2.15–2.11 (m, 2H), 2.08 (s, 3H), 2.08 (s, 3H), 1.73–1.67 (m, 2H). ^{13}C NMR (CDCl_3 , 75 MHz): δ 206.2, 171.7, 165.5, 165.3, 165.1, 138.5, 138.3, 138.2, 138.0, 137.9, 137.6, 133.3, 133.2, 133.1, 129.9, 129.8, 129.7, 129.6, 129.5, 129.4, 128.5, 128.4, 128.3, 128.2, 128.0, 127.9, 127.8, 127.7, 127.1, 127.6, 127.5, 114.7, 106.4, 106.2, 106.1, 106.0, 105.2, 98.2, 83.4, 83.2, 83.0, 82.9, 82.4, 82.3, 81.9, 81.8, 81.7, 81.5, 80.0, 78.3, 75.1, 74.0, 73.4, 72.3, 72.2, 72.0, 71.8, 71.5, 71.4, 68.7, 68.5, 66.8, 66.2, 66.1, 65.8, 65.5, 65.1, 38.0, 30.2, 29.7, 28.6, 28.2. IR (CHCl_3): ν_{max} 3066, 3008, 2932, 2872, 1721, 1452, 1363, 1299, 1114, 1028 cm^{-1} . MALDI-HRMS calcd for $\text{C}_{176}\text{H}_{180}\text{O}_{45}\text{Na}$ (m/z): $[\text{MNa}^+]$ 3036.1694, found 3036.1615.

Pent-4-enyl 5-O-(5-O-(2-O-Benzoyl-3-O-benzyl-5-O-(3,4,6-tri-O-benzyl- α -D-mannopyranosyl)- α -D-arabinofuranosyl)-2-O-benzoyl-3-O-(5-O-(2-O-benzoyl-3-O-benzyl-5-O-(3,4,6-tri-O-benzyl- α -D-mannopyranosyl)- α -D-arabinofuranosyl)-2-O-benzoyl-3-O-benzyl- α -D-arabinofuranosyl)- α -D-arabinofuranosyl)-2-O-benzoyl-3-O-benzyl- α -D-arabinofuranosyl)-2-O-benzoyl-3-O-benzyl- α -D-arabinofuranoside (54). Octasaccharide **53** (0.090 g, 0.0298 mmol) was dissolved in CH_2Cl_2 (1.3 mL), and premixed AcOH/pyridine (0.037 mL/0.063 mL) followed by hydrazine monohydrate (0.0064 mL, 0.132 mmol) were added. After 2 h at room temperature the reaction was quenched with acetone and the solvents were evaporated. Purification by gradient flash silica gel column chromatography (hexanes/EtOAc, 2:1 to 1:1) gave **54** (0.067 g, 80%) as a colorless oil. $R_f = 0.25$ (hexanes/EtOAc, 1:1). $[\alpha]_{\text{D}} = +85.1$ (c 0.75, CHCl_3). ^1H NMR (CDCl_3 , 300 MHz): δ 8.04–7.94 (m, 12H), 7.53–7.03 (m, 73H), 5.84–5.76 (m, 1H), 5.48 (s, 1H), 5.43

(d, $J = 1.5$ Hz, 1H), 5.37 (d, $J = 1.5$ Hz, 1H), 5.36 (s, 3H), 5.28 (s, 1H), 5.26 (s, 1H), 5.25 (d, $J = 1.1$ Hz, 1H), 5.22 (s, 1H), 5.14 (s, 1H), 5.10 (s, 1H), 5.02–4.91 (m, 4H), 4.75 (d, $J = 12.0$ Hz, 1H), 4.73 (d, $J = 10.9$ Hz, 1H), 4.72 (d, $J = 11.1$ Hz, 1H), 4.70 (d, $J = 13.0$ Hz, 1H), 4.63 (d, $J = 12.0$ Hz, 1H), 4.62 (d, $J = 10.5$ Hz, 1H), 4.59 (d, $J = 10.0$ Hz, 1H), 4.58 (d, $J = 12.3$ Hz, 1H), 4.57 (d, $J = 12.0$ Hz, 1H), 4.52 (d, $J = 12.0$ Hz, 1H), 4.51 (d, $J = 12.1$ Hz, 1H), 4.50 (d, $J = 12.1$ Hz, 1H), 4.46–4.41 (m, 6H), 4.37–4.12 (m, 13H), 3.98–3.53 (m, 28H), 3.45 (td, $J = 6.6, 9.8$ Hz, 1H), 2.50 (d, $J = 2.0$ Hz, 1H), 2.42 (d, $J = 2.3$ Hz, 1H), 2.15–2.10 (m, 2H), 1.72–1.67 (m, 2H). ^{13}C NMR (CDCl_3 , 75 MHz): δ 165.5, 165.3, 165.1, 138.4, 138.3, 138.2, 137.9, 137.8, 137.7, 137.6, 133.4, 133.2, 133.1, 129.9, 129.8, 129.7, 129.6, 129.5, 129.4, 128.5, 128.4, 128.3, 128.2, 127.8, 127.7, 127.6, 127.5, 114.8, 106.2, 106.1, 106.0, 105.3, 99.6, 99.5, 83.4, 83.2, 83.0, 82.8, 82.6, 82.3, 82.1, 81.9, 81.7, 81.5, 80.2, 80.1, 79.9, 75.0, 74.1, 74.0, 73.4, 72.4, 72.3, 72.2, 72.0, 71.9, 71.6, 71.5, 71.3, 68.8, 68.0, 67.9, 66.8, 65.8, 65.6, 65.5, 65.4, 65.3, 30.2, 28.7. IR (CHCl_3): ν_{max} 3562, 3066, 3008, 2927, 1723, 1452, 1299, 1114, 1071, 1028 cm^{-1} . MALDI-HRMS calcd for $\text{C}_{166}\text{H}_{168}\text{O}_{41}\text{Na}$ (m/z): $[\text{MNa}^+]$ 2840.0959, found 2840.1035.

Acknowledgment. This research was supported by the ETH Zürich (ETH Grant No. TH-37/05-1), the Deutsche Forschungsgemeinschaft (Emmy Noether postdoctoral fellowship for A.H.), and the Foundation for Research, Science and Technology, New Zealand (postdoctoral fellowship for B.L.S). We thank Simone Bufali, Christian Noti, and Mattie Timmer for their help with the acquisition of high-field NMR spectra, as well as Marian Kehl and Kyrill Stanek for their help in the preparation of intermediates.

Supporting Information Available: Full experimental data for all new mannose and arabinose building blocks and spectral data (^1H and ^{13}C NMR) of all new compounds. This material is available free of charge via the Internet at <http://pubs.acs.org>.

JO061233X